

OPERATION AND PARTS MANUAL



Mikasa SERIES
MODEL MVH-150D2
REVERSIBLE PLATE COMPACTOR
(YANMAR L48V6 DIESEL ENGINE)

Revision #2 (01/16/07)

To find the latest revision of this
publication, visit our website at:
www.multiquip.com



THIS MANUAL MUST ACCOMPANY THE EQUIPMENT AT ALL TIMES.



CALIFORNIA — Proposition 65 Warning

Engine exhaust and some of its constituents are known to the State of California to cause cancer, birth defects and other reproductive harm.

MVH-150D2 — TABLE OF CONTENTS

MQ MIKASA SERIES MVH-150D2 PLATE COMPACTOR

Proposition 65 Warning	2
Table Of Contents	4
Parts Ordering Procedures	5
Safety Message Alert Symbols	6-7
Rules for Safe Operation	8-9
Dimensions	10
Specifications	11
General Information	12
Plate Compactor Components	13
Engine Components	14
Inspection	15-16
Operation	17-18
Preparation For Long term Storage	18
Maintenance	19-21
Troubleshooting (Engine)	22
Troubleshooting (Compactor)	23
Explanation Of Code In Remarks Column	24
Suggested Spare Parts	25

COMPONENT DRAWINGS

Nameplate and Decal (Placement)	26-27
Vibrating Plate Assembly	28-29
Body Assembly	30-31
Vibrator Assembly	32-33
Control Assembly	34-37
Hand Pump Assembly	38-39

YANMAR L48V6F3R4AAW4 ENGINE

Cylinder Block Assembly	40-41
Cylinder Head Assembly	42-43
Air Cleaner Assembly	44-45
Muffler Assembly	46-47
Crankshaft and Camshaft Assembly	48-49
Piston Assembly	50-51
Lub. Oil Pump and Governor Assembly	52-53
Cooling and Starting Device Assembly	54-55
Fuel Injection Pump Assembly	56-57
Fuel Tank and Fuel Line Assembly	58-59
Tools, Labels and Gasket Set Assembly	60-61
Terms and Conditions Of Sale — Parts	62

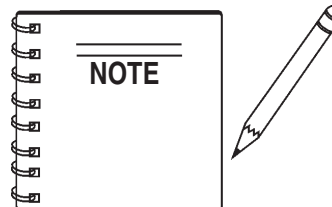

Specification and part number are subject to change without notice.

www.multiquip.com

**Ordering parts has never been easier!
Choose from three easy options:**



Order via Internet (Dealers Only):

Order parts on-line using Multiquip's SmartEquip website!

- View Parts Diagrams
- Order Parts
- Print Specification Information



If you have an MQ Account, to obtain a Username and Password, E-mail us at: parts@multiquip.com.

To obtain an MQ Account, contact your District Sales Manager for more information.

Goto www.multiquip.com and click on

Order Parts to log in and save!

Use the **internet** and qualify for a **5% Discount** on *Standard orders* for all orders which include complete part numbers.*

Note: Discounts Are Subject To Change



Order via Fax (Dealers Only):

All customers are welcome to order parts via Fax.

Domestic (US) Customers dial:
1-800-6-PARTS-7 (800-672-7877)

Fax your order in and qualify for a **2% Discount** on *Standard orders* for all orders which include complete part numbers.*

Note: Discounts Are Subject To Change



Order via Phone: Domestic (US) Dealers Call:
1-800-427-1244

Non-Dealer Customers:

Contact your local Multiquip Dealer for parts or call 800-427-1244 for help in locating a dealer near you.



International Customers should contact their local Multiquip Representatives for Parts Ordering information.

When ordering parts, please supply:

- | | |
|---|--|
| <input type="checkbox"/> Dealer Account Number | <input type="checkbox"/> Specify Preferred Method of Shipment: |
| <input type="checkbox"/> Dealer Name and Address | <input checked="" type="checkbox"/> UPS/Fed Ex <input checked="" type="checkbox"/> DHL |
| <input type="checkbox"/> Shipping Address (if different than billing address) | <input type="checkbox"/> Priority One <input checked="" type="checkbox"/> Truck |
| <input type="checkbox"/> Return Fax Number | <input type="checkbox"/> Ground |
| <input type="checkbox"/> Applicable Model Number | <input type="checkbox"/> Next Day |
| <input type="checkbox"/> Quantity, Part Number and Description of Each Part | <input type="checkbox"/> Second/Third Day |

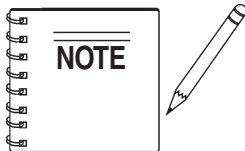

All orders are treated as *Standard Orders* and will ship the same day if received prior to 3PM PST.

WE ACCEPT ALL MAJOR CREDIT CARDS!



MVH-150D2 — SAFETY MESSAGE ALERT SYMBOLS

FOR YOUR SAFETY AND THE SAFETY OF OTHERS!

Safety precautions should be followed at all times when operating this equipment. Failure to read and understand the Safety Messages and Operating Instructions could result in injury to yourself and others.

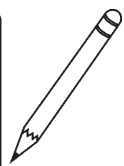
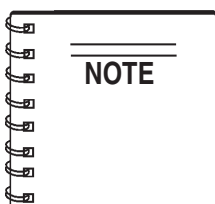

This Owner's Manual has been developed to provide complete instructions for the safe and efficient operation of the Multiquip Model MVH-150D2 Reversible Plate Compactor.

Refer to the engine manufacturer's instructions for data relative to its safe operation.

Before using this plate compactor, ensure that the operating individual has read and understands all instructions in this manual.

SAFETY MESSAGE ALERT SYMBOLS

The three (3) Safety Messages shown below will inform you about potential hazards that could injure you or others. The Safety Messages specifically address the level of exposure to the operator, and are preceded by one of three words: **DANGER**, **WARNING**, or **CAUTION**.

DANGER

You **WILL** be **KILLED** or **SERIOUSLY INJURED** if you **DO NOT** follow these directions.

WARNING

You **CAN** be **KILLED** or **SERIOUSLY INJURED** if you **DO NOT** follow these directions.

CAUTION

You **CAN** be **INJURED** if you **DO NOT** follow these directions.

Potential hazards associated with the operation of an **MVH-150D2 Plate Compactor** will be referenced with Hazard Symbols which appear throughout this manual, and will be referenced in conjunction with Safety Message Alert Symbols.

HAZARD SYMBOLS

WARNING - Lethal Exhaust Gases

Engine exhaust gases contain poisonous carbon monoxide. This gas is colorless and odorless, and can cause death if inhaled. **NEVER** operate this equipment in a confined area or enclosed structure that does not provide ample free flow air.



WARNING - Explosive Fuel

Diesel fuel is extremely flammable, and its vapors can cause an explosion if ignited. **DO NOT** start the engine near spilled fuel or combustible fluids.



DO NOT fill the fuel tank while the engine is running or hot. **DO NOT** overfill tank, since spilled fuel could ignite if it comes into contact with hot engine parts or sparks from the ignition system. Store fuel in approved containers, in well-ventilated areas and away from sparks and flames.

WARNING - Burn Hazards

Engine components can generate extreme heat. To prevent burns, **DO NOT** touch these areas while the engine is running or immediately after operations. Never operate the engine with heat shields or heat guards removed.



CAUTION - Respiratory Hazard

ALWAYS wear approved **respiratory** protection when required.



MVH-150D2 — SAFETY MESSAGE ALERT SYMBOLS

CAUTION - Rotating Parts

NEVER operate equipment with covers, or guards removed. Keep fingers, hands, hair and clothing away from all moving parts to prevent injury.



CAUTION - Equipment Damage Messages

Other important messages are provided throughout this manual to help prevent damage to your COMPACTOR, other property, or the surrounding environment.

CAUTION - Sight and Hearing Hazards

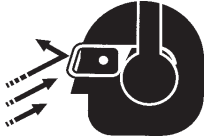

ALWAYS wear approved eye and hearing protection.

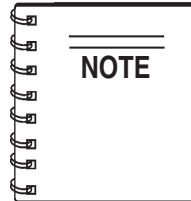

This plate compactor, other property, or the surrounding environment could be damaged if you do not follow instructions.

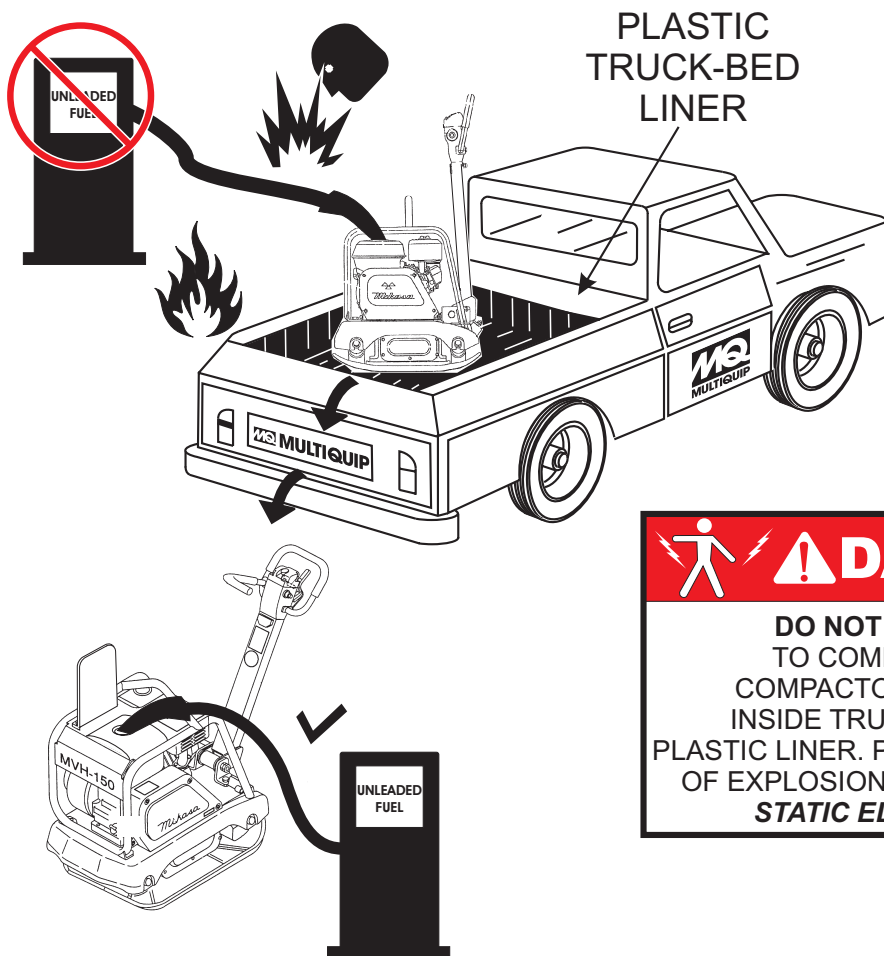

 **! DANGER**

DO NOT ADD FUEL TO COMPACTOR IF COMPACTOR IS PLACED INSIDE TRUCK-BED WITH PLASTIC LINER. POSSIBILITY EXISTS OF EXPLOSION OR FIRE DUE TO *STATIC ELECTRICITY*.

MVH-150D2 — RULES FOR SAFE OPERATION

DANGER - Read Manual

Failure to follow instructions in this manual may lead to serious injury or even death! This equipment is to be operated by trained and qualified personnel only! This equipment is for industrial use only.



The following safety guidelines should always be used when operating the **compact**or.

GENERAL SAFETY

- **DO NOT** operate or service this equipment before reading this entire manual.
- This equipment should not be operated by persons under 18 years of age.
- **NEVER** operate this equipment without proper protective clothing, shatterproof glasses, steel-toed boots and other protective devices required by the job.



- **NEVER** operate this equipment when not feeling well due to fatigue, illness or taking medicine.



- **NEVER** operate this equipment under the influence of drugs or alcohol.



- Whenever necessary, replace nameplate, operation and safety decals when they become difficult read.
- **ALWAYS** check the machine for loosened threads or bolts before starting.
- **ALWAYS** wear proper respiratory (mask) hearing and eye protection equipment when operating the pump.

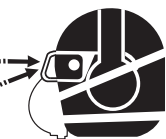

- **NEVER** touch the hot exhaust manifold, muffler or cylinder. Allow these parts to cool before servicing engine or plate compactor.



- **High Temperatures** – Allow the engine to cool before adding fuel or performing service and maintenance functions. Contact with *hot* components can cause serious burns.

- The engine of this compactor requires an adequate free flow of cooling air. **NEVER!** operate the compactor in any enclosed or narrow area where free flow of the air is restricted. If the air flow is restricted it will cause serious damage to the compactor or engine and may cause injury to people and property. Remember the engine gives off **DEADLY** gases.

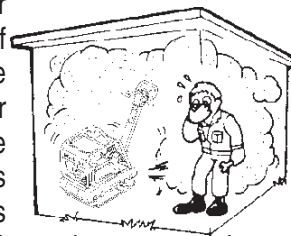

- **ALWAYS** refuel in a well-ventilated area, away from sparks and open flames.

- **ALWAYS** use extreme caution when working with **flammable** liquids. When refueling, **stop the engine** and allow it to cool. **DO NOT** smoke around or near the machine. Fire or explosion could result from fuel vapors, or if fuel is spilled on a hot engine.



- **NEVER** operate the equipment in an **explosive atmosphere** or near combustible materials. An explosion or fire could result causing severe **bodily harm or even death**.

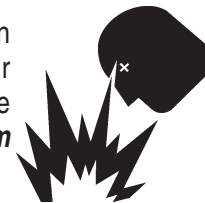

- Topping-off to filler port is dangerous, as it tends to spill fuel.
- Refer to the **Engine Owner's Manual** for engine technical questions or information.
- **NEVER** use accessories or attachments, which are not recommended by Multiquip for this equipment. Damage to the equipment and/or injury to user may result.
- Manufacturer does not assume responsibility for any accident due to equipment modifications.

MVH-150D2 — RULES FOR SAFE OPERATION

Loading and Unloading

- Before lifting compactor, make sure that machine parts, guard hook, and vibration insulators are not damaged and screws are not loosened or lost.
- When using a crane or lifting device, always make sure that it is properly secured to the guard hook on the compactor.



- **NEVER** lift the machine while the engine is running.
- **ALWAYS** use an adequate lifting chain, strap or rope of sufficient strength.
- Use one point suspension hook and lift straight upwards.
- **NEVER** allow any person or animal to stand underneath the machine while lifting.
- Try not to lift machine to unnecessary heights

TRANSPORTING

- **ALWAYS** shutdown engine before transporting.
- Tighten fuel tank cap securely and close fuel cock to prevent fuel from spilling.
- Drain fuel when transporting compactor over long distances or bad roads.
- **ALWAYS** tie down the compactor during transportation by securing the compactor's guard frame with ropes so that it will not move or topple over.

Maintenance Safety

- **NEVER** lubricate components or attempt service on a running machine.
- **ALWAYS** allow the machine a proper amount of time to cool before servicing.
- Keep the machinery in proper running condition.
- Fix damage to the machine immediately and always replace broken parts.
- Dispose of hazardous waste properly. Examples of potentially hazardous waste are used motor oil, fuel and fuel filters.
- **DO NOT** use food or plastic containers to dispose of hazardous waste.
- **DO NOT** pour waste, oil or fuel directly onto the ground, down a drain or into any water source.
- Removing the engine oil drain plug while the engine is hot will result in hot oil to gush out of the oil drain plug, therefore causing severe scalding to any persons in the general area of the generator.



Emergencies

- **ALWAYS** know the location of the nearest **fire extinguisher**.



- **ALWAYS** know the location of the nearest **first aid kit**.

- In emergencies **always** know the location of the nearest phone or **keep a phone on the job site**. Also know the phone numbers of the nearest **ambulance, doctor and fire department**. This information will be invaluable in case of an emergency.

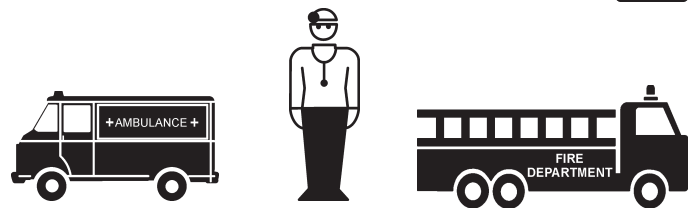

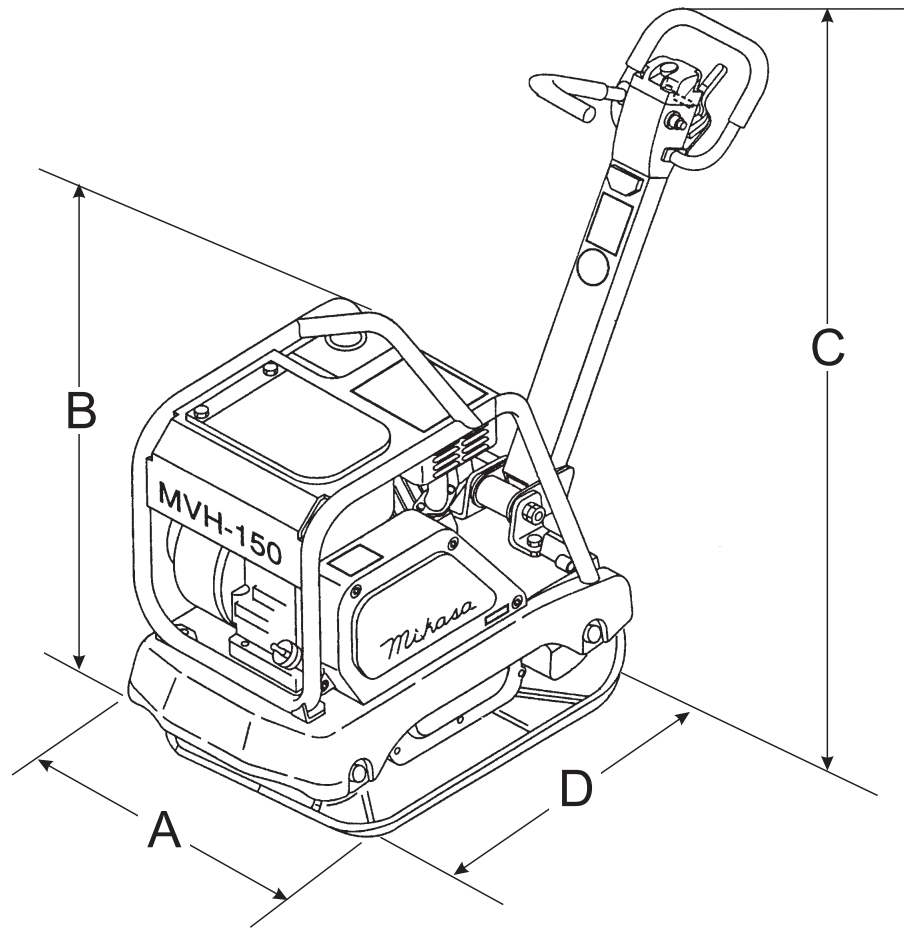

Figure 1. MVH-150D2 Reversible Plate Compactor Dimensions

TABLE 1. DIMENSIONS	
REFERENCE LETTER	DIMENSIONS IN. (MM)
A	17.0 in. (432 mm.)
B	30.5 in. (775 mm.)
C	43 in. (1,092 mm.)
D	26.0 in. (660 mm.)

TABLE 2. Specifications (Compactor)

Models	MVH-150D2
Centrifugal Force	6,620 lbs. (3,002 kg)
Number of Vibrations	5,600 vibrations/min
Traveling Speed	75 ft./min (23 meters/min)
Plate Size (LxW)	17.0 x 26.0 in. (430 x 700 mm)
Operating Weight	357 lbs. (162 kg)

Table 3. Specifications (Engine)

	Model	YANMAR L48V6F3R4AAW4
Engine	Type	Air-cooled 4 stroke, Vertical Single Cylinder, Diesel Engine
	Bore X Stroke	2.7 in. x 1.8 in. (70 mm x 57 mm)
	Displacement	219 cc (13.4 cu-in)
	Max Output	4.2 H.P./3600 R.P.M.
	Fuel Tank Capacity	Approx. 0.63 U.S. gallons (2.4 liters)
	Fuel	Diesel Fuel
	Lube Oil Capacity	0.84 qts. (.80 liters)
	Starting Method	Recoil Start
Dimension (L x W x H)	13.1 x 15.1 x 16.5 in. (332.5 x 384.5 x 417.8 mm)	
Dry Net Weight	58.4 lbs (26.5 Kg.)	

Plate Compactor

The Mikasa MVH-150D2 is a walk-behind reversible plate compactor designed for the compaction of sand, clay and asphalt. This plate compactor is a powerful compacting tool capable of applying a tremendous force in consecutive high frequency vibrations to a soil surface. Its applications include soil compacting for road, embankments and reservoirs as well as backfilling for gas pipelines, water pipelines and cable installation work.

Compactor Components

This plate compactor is comprised of an anti-vibration handle, vibrating case (eccentric), water tank, guard hook, rubber shock absorbers and a Yanmar diesel engine.

Reversible Vibratory Plates

Reversible vibratory plates have two eccentric weights that allow a smooth transition for forward and reverse travel, plus increased compaction force as the result of dual weights.

Due to their weight and force, reversible plates are ideal for semi-cohesive soils.

Power Transfer

The Mikasa MVH-150D2 Plate Compactor is equipped with an air-cooled, vertical single-cylinder, 4-stroke Yanmar L48V6 diesel engine. A centrifugal clutch is attached to the output shaft of the engine and will engage when the engine speed reaches approximately 2,300 ~ 2,600 rpm's.

Engine shaft speed is transferred via engine pulley and V-belt to vibrator pulley. The vibrator pulley rotates an eccentric rotor shaft (2) one for forward one for reverse that is contained within the vibrator case.

The generated vibration created from the eccentric rotor is transmitted to the compacting plate. This vibration causes the compactor to move in either a forward or reverse direction.

Frequency/Speed

The compactor's vibrating plate maximum frequency is 6,000 vpm (vibrations per minute). The forward and reverse travel speed of the compactor is approximately 75ft./minute (23 meters/minute).

Controls

Before starting the MVH-150D2 Plate Compactor, identify and understand the function of the controls and components as indicated in Figure 2.

MVH-150D2 — COMPONENTS (PLATE COMPACTOR)

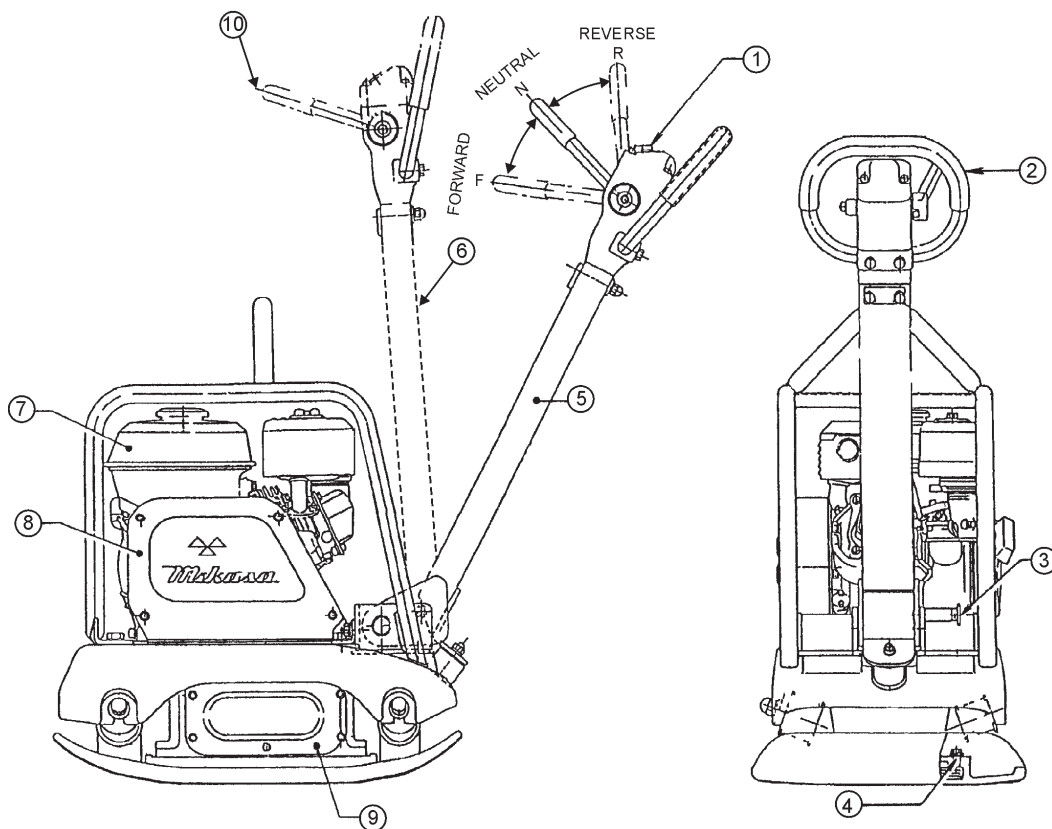

Figure 2. MVH-150D2 Components

Figure 2 shows the location of the controls, indicators and general maintenance parts. The function of each control is described below:

1. **Breather Cap** – Remove this cap to bleed (remove air) the hydraulic system. When replacing hydraulic oil, use "Shell Tellus #46 or equivalent".
2. **Hand Grip** – When operating the compactor use this hand grip to maneuver the compactor.
3. **Handle Lock** – Pull handle bar downward (working position), then pull handle lock to lock handle bar in place.
4. **Vibration Case Oil Level Check Plug** – Remove this plug to check the vibration case oil. Oil level should be all the way up to the filler port. When replacing vibration case oil, use 10W-30 engine oil.
5. **Handle Bar (working position)** – When operating the compactor, this handle is to be in the downward position.
6. **Handle Bar (stored position)** – When the compactor is to be **stored**, move the handle bar to the upright position.
7. **Engine** – This plate compactor use a **YANMAR L48V6** diesel engine. Refer to the owner's manual for engine information and related topics.
8. **Belt Cover** – Remove this cover to gain access to the V-belts. **NEVER** run the compactor without the V-belt cover. If the V-belt cover is not installed, the possibility exist that your hand may get caught between the V-belt and clutch, thus causing serious injury and bodily harm.
9. **Vibration Case** – Encloses the eccentric, gears and counter weights.
10. **Forward and Reverse Lever** – **Push** the lever forward, the compactor will move in a forward direction, **pull** the lever backwards, the compactor will move in backwards direction. Placing the lever in the middle (midway) will cause the compactor not to move (neutral).

MVH-150D2 — COMPONENTS (YANMAR L48V6 ENGINE)

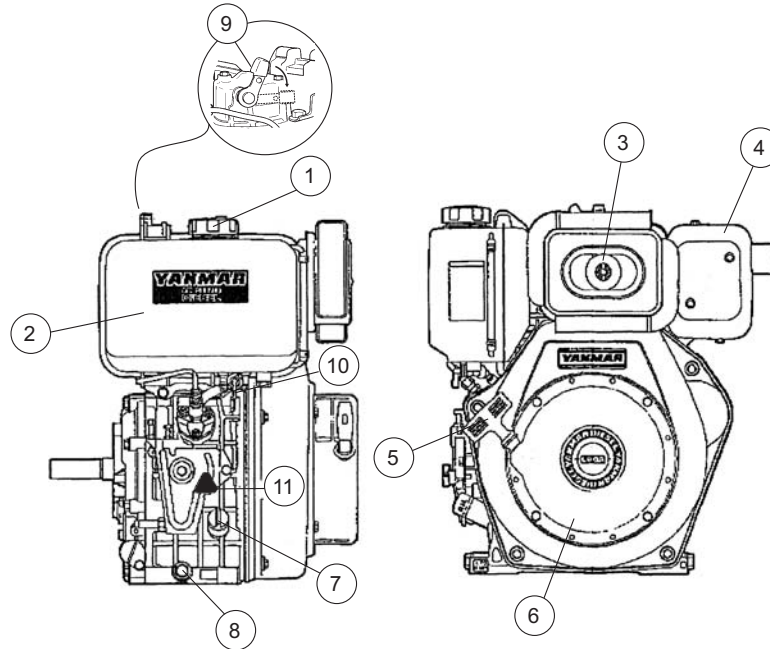

Figure 3. Engine Controls and Components

The engine shown above is a **YANMAR L48V6** engine (Figure 3). The engine must be checked for proper lubrication and filled with fuel prior to operation. Refer to the manufacturer's engine manual for instructions and details of operation and servicing. Each component is described below:

1. **Fuel Filler Cap** – Remove this cap to add unleaded gasoline to the fuel tank. Make sure cap is tightened securely. **DO NOT** over fill.
2. **Fuel Tank** – Capacity is 2.5 quarts (2.4 liters) of diesel fuel.
3. **Air Cleaner** – Prevents dirt and other debris from entering the fuel system. Remove wing-nut on top of air filter canister to gain access to filter element.
4. **Muffler** – Used to reduce noise and emissions.
5. **Recoil Starting Handle (pull rope)** – Type of engine starting method.

! DANGER - Explosive Fuel Hazard

Adding fuel to the tank should be done only when the engine is stopped and has had an opportunity to cool down. In the event of a fuel spill, **DO NOT** attempt to start the engine until the fuel residue has been completely wiped up, and the area surrounding the engine is dry.

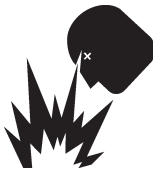

6. **Recoil Starter**– Manual-starting method. Pull the starter grip until resistance is felt, then pull briskly and smoothly.

7. **Oil Filler Cap / Dipstick** – Remove this cap to add oil to the engine crankcase. Read dipstick to determine if oil level is low. **DO NOT** over fill.

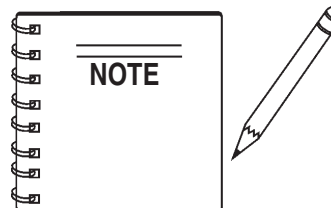

Operating the engine without an air filter, with a damaged air filter, or a filter in need of replacement will allow dirt to enter the engine, causing rapid engine wear.

8. **Oil Drain Plug** – Unscrew plug to drain oil from engine crankcase. Dispose of oil in a safe manner.
9. **Decompression Lever**– Press down before starting engine. To prevent damage to engine, **DO NOT** use for any other purpose.

! CAUTION - Burn Hazard

Engine components can generate extreme heat. To prevent burns, **DO NOT** touch these areas while the engine is running or immediately after operating. **NEVER** operate the engine with the muffler removed.



10. **Fuel Cock**– Controls the flow of diesel fuel to the carburetor. Must be in the ON position when starting and running the engine.
11. **Speed Control Lever**– Regulates engine speed.

CAUTION - General Safety Precautions

NEVER operate the compactor in a confined area or enclosed area structure that does not provide ample **free flow of air**.



ALWAYS wear approved eye and hearing protection before operating the compactor.



Before Starting:

1. Read safety instructions at the beginning of manual.
2. Remove dirt and dust, particularly in the engine cooling air inlet, carburetor and air cleaner.
3. Check the air filter for dirt and dust. If air filter is dirty, replace air filter with a new one as required.
4. Check carburetor for external dirt and dust. Clean with dry compressed air.
5. Check fastening nuts and bolts for tightness.



Engine Oil Check:

1. To check the engine oil level, place the compactor on secure level ground with the engine stopped.
2. Remove the filler dipstick from the engine oil filler hole (Figure 5) and wipe clean.

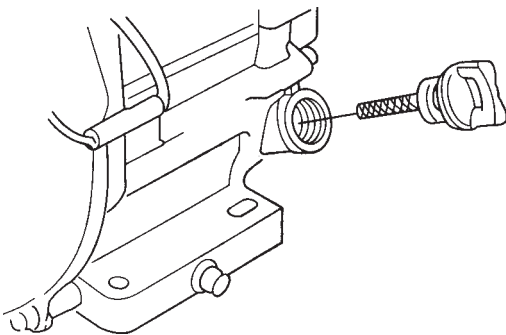

Figure 5. Engine Oil Dipstick (Removal)

3. Insert and remove the dipstick without screwing it into the filler neck. Check the oil level shown on the dipstick.
4. If the oil level is low (Figure 6), fill to the edge of the oil filler hole with the recommended oil type (Table 4). Maximum oil capacity is 0.84 quarts (0.80 liters).

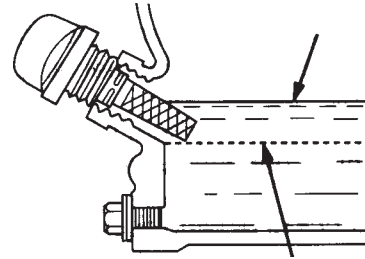

Figure 6. Engine Oil Dipstick (Oil Level)

DANGER - Explosive Fuel

Diesel is extremely flammable, and its vapors can cause an explosion if ignited. **DO NOT** start the engine near spilled fuel or combustible fluids. **DO NOT** smoke while refueling. **DO NOT** attempt to refuel the compactor if the engine is **hot!** or **running**.



Fuel Check:

1. Remove the fuel cap located on top of fuel tank.
2. Visually inspect to see if the fuel level is low. If fuel is low, replenish with clean diesel fuel.
3. When refueling, be sure to use a strainer for filtration. **DO NOT** top-off fuel. Wipe up any spilled fuel **immediately!**

V-Belt Check

⚠ CAUTION - V-Belt Check

NEVER attempt to check the V-belt with the engine running. Severe injury can occur if your hand (Figure 7) gets caught between the V-belt and the clutch. Always use safety gloves.

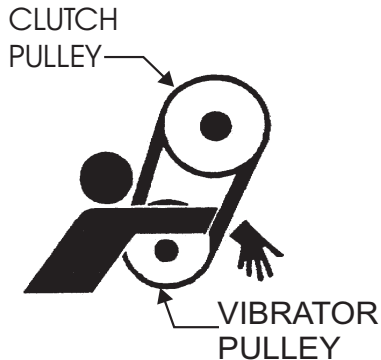

Figure 7. V-Belt Hazard

1. To check the V-belt tension (Figure 8), remove **upper** belt cover.

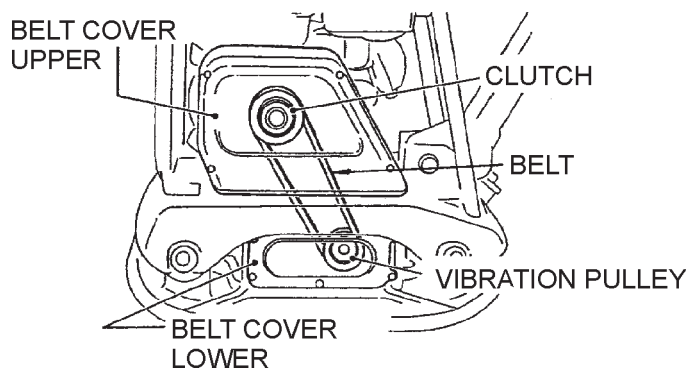

Figure 8. V-Belt Cover Removal

2. The V-belt tension is proper if the V-belt bends 10 to 15 mm (Figure 9) when depressed with finger at midway between the clutch and vibration pulley shafts.

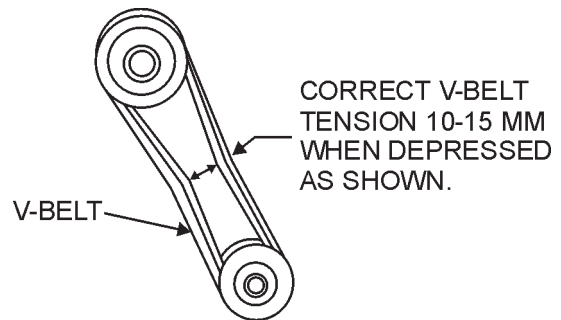

Figure 9. V-Belt Tension

3. A loose V-belt will decrease the power transmission output, causing reduced compaction and premature wear of the belt.
4. If the V-belt becomes worn or loose, replace it. See maintenance section.

Vibrator Oil Check

1. Place the MVH-150D2 plate compactor horizontally on a flat surface. Make sure the compactor is level when checking the oil in the vibrator assembly.
2. With the handle bar positioned vertically (storage position), use a 24 mm wrench and remove breather plug (Figure 10). Visually check to see if hydraulic oil comes up to the oil level line that is etched on the back side of the handle.

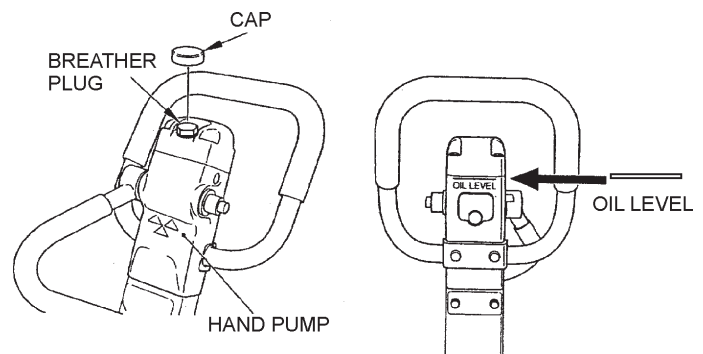

Figure 10. Vibrator Oil Plug

3. If the hydraulic oil level is low, replace with "**Shell Tellus**" oil #46 or equivalent.

This section is intended to assist the operator with the **initial start-up** of the compactor. It is extremely important that this section be read carefully before attempting to use the compactor in the field.

Starting the Engine

1. Open the fuel cock (Figure 11).

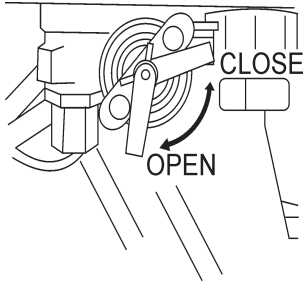

Figure 11. Fuel Cock

2. Move the engine speed control lever (Figure 12) to the **IDLE** position.

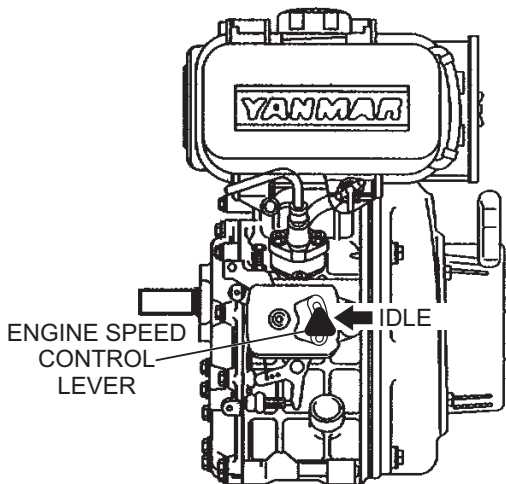

Figure 12. Engine Speed Control Lever (Idle Position)

3. Push down the decompression lever (Figure 13) and release.

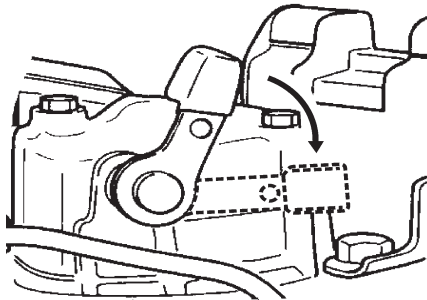

Figure 13. Decompression Lever

4. Grasp the starter grip (Figure 14) and slowly pull it out. The resistance becomes the hardest at a certain position, corresponding to the compression point. Pull the starter grip briskly and smoothly for starting.

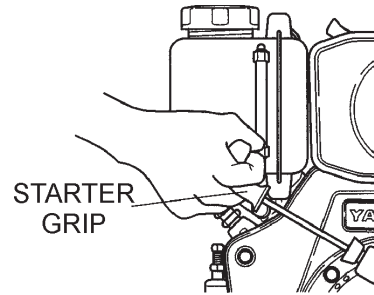

Figure 14. Starter Grip

5. If the engine does not start, repeat steps 1 thru 4.

Operation

1. Once the engine has started, move the engine speed lever quickly to the **FAST** (Figure 15) position.
2. With the engine speed control lever placed in the **FAST** position, the engine speed should be between 2,300 ~2,600 RPM's, therefore engaging the centrifugal clutch.

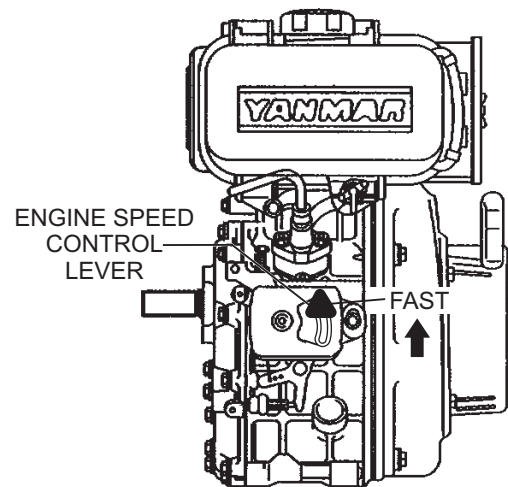
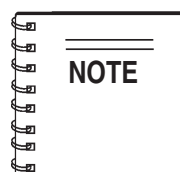

Figure 15. Speed Control Lever (Fast Position)



ALWAYS move the throttle lever quickly without hesitation, because increasing the engine speed slowly causes the clutch to slip.

MVH-150D2 — OPERATION/PREPARATION FOR LONG TERM STORAGE

CAUTION - Safety Rules

Make sure to follow all safety rules referenced in the safety section of this manual before operating compactor. Keep work area clear of debris and other objects that could cause damage to the compactor or bodily injury.

3. To make the compactor move in the forward direction push the travel lever (Figure 16) forward. To make the compactor move in the reverse direction pull the travel lever backwards.

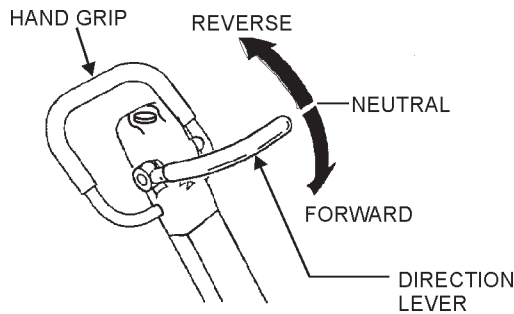
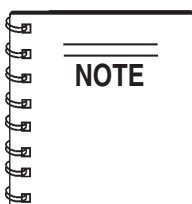

Figure 16. Direction Lever

4. Firmly gasp the compactor's handle bar with both hands, the compactor will begin moving forward.
5. Slowly walk behind the compactor and be on the lookout for any large objects or foreign matter that might cause damage to the compactor or bodily injury.
6. Compactor traveling speed may drop on soils which contain clay, however there may be cases where traveling speed drops because the compaction plate does not leave the ground surface easily due to the composition of the soil. To rectify this problem do the following:
 - Check the bottom plate to see if clay or equivalent material has been lodged in the plate mechanism. If so, wash with water and remove.
 - Remember the compactor does not work as efficiently on clay or soils that have a high moisture content level.
 - If the soil has a high moisture level, dry soil to appropriate moisture content level or carry out compaction twice.



Whenever the compactor's vibration becomes weak or lost during normal operation, regardless of operation hours, check the V-belt and clutch immediately.

Normal Shut-Down Procedure:

1. Place the speed control lever in the **IDLE** position. Allow the engine to cool down for 2 to 3 minutes.
2. Next, place the speed control lever in the **STOP** position (Figure 17) to stop the engine.
3. Close the fuel cock (Figure 11).

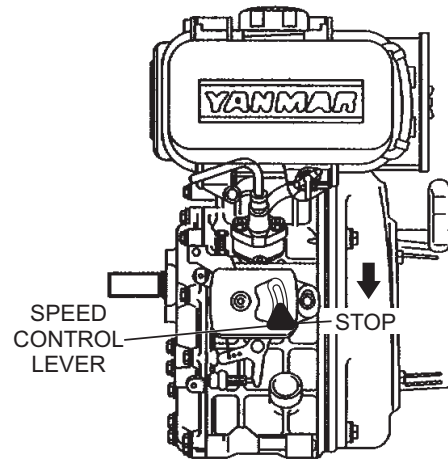

Figure 17. Speed Control Lever (Stop Position)

Emergency Shutdown Procedure:

1. Move the speed control lever quickly to the **STOP** position (Figure 17).
2. Close the fuel cock.

Compactor Storage

For storage of the compactor for over 30 days, the following is required:

- Drain the fuel tank completely, or add STA-BIL to the fuel.
- Run the engine until the fuel in the injection system is completely consumed.
- Completely drain the oil from the crankcase and refill with fresh oil.
- Pour 2 or 3 cc of SAE 30 oil into the cylinder and crank slowly to distribute the oil.
- Pull out the starter rope slowly and stop at the compression point.
- Clean all external parts of the compactor with a cloth.
- Cover the compactor and store in a clean, dry place.

CAUTION - General Maintenance Safety

Inspection and other services should **always** be carried out on hard and level ground with the engine shutdown.

Inspection and Maintenance Service Tables.

To make sure your plate compactor is always in good working condition before using, carry out the maintenance inspection in accordance with Tables 5 through 7.

TABLE 5. MACHINE INSPECTION

Item	Hours of Operation
(Starting check)	Every 8 hours (every day)
Loosened or lost screws	Every 8 hours (every day)
Damage of any part	Every 8 hours (every day)
Function of controlling system part	Every 8 hours (every day)
Leak of hydraulic system	Every 100 hours
Vibrator oil check	Every 300 hours
Vibrator oil replacement	Every 100 hours
Hydraulic oil check	Every 200 hours, then in every 1000 hrs.
V-belt (clutch) check	Every 200 hour

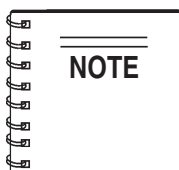

These inspection intervals are for operation under normal conditions. Adjust your inspection intervals based on the number hours plate compactor is in use, and particular working conditions. Fuel piping and connections should be replaced every 2 years.

TABLE 6. MVC-150D2 ENGINE CHECK

ITEM	HOURS OF OPERATION
Oil or Fuel Leak	Every 8 hours (every day)
Tightness of Fastening Threads	Every 8 hours (every day)
Engine Oil Check and Replenishment	Every 8 hours (every day) (Replenish to specified maximum level)
Engine Oil Replacement	After first 25 hours then every 50 to 100 hours
Air Filter Cleaning	Every 100 hours
See separate engine manual for details on engine maintenance.	

Daily Service

- Check for leakage of fuel or oil.
- Check for loose screws including tightness. See Table 7 below (tightening torque), for retightening:

TABLE 7.

TIGHTENING TORQUE (in. kg/cm) Diameter

Material	6mm	8mm	10mm	12mm	14mm	16mm	18mm	20mm
4T	70	150	300	500	750	1,100	1,400	2,000
6-8T	100	250	500	800	1,300	2,000	2,700	3,800
11T	150	400	800	1,200	2,000	2,900	4,200	5,600
*	100	300~ 350	650 ~ 700					

* (In case counter-part is of aluminum)
(Threads in use with this machine are all right handed)
Material and quality of material is marked on each bolt, and screw.

- Remove soil and clean the bottom of compaction plate.
- Check vibrating case for any oil leakage.
- Check engine oil.

Engine Oil Replacement

1. Replace engine oil, first in 25 hours of operation and every 50 to 100 hours afterwards.
2. Drain the engine oil when the oil is **warm** as shown in Figure 18.

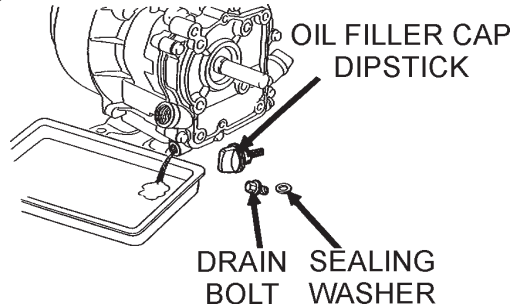

Figure 18. Engine Oil (Draining)

3. Remove the oil drain bolt and sealing washer and allow the oil to drain into a suitable container.
4. Replace engine oil in the oil tank with recommended type oil as listed in Table 4. Engine oil capacity is 1.16 quarts (1.1 liter). **DO NOT** overfill.
5. Install drain bolt with sealing washer and tighten securely.

Air Filter Cleaning

1. Remove the air cleaner cover and foam filter element as shown in Figure 19.
2. Tap the paperfilter element (Figure 19) several times on a hard surface to remove dirt, or blow compressed air [not exceeding 30psi (207 kPa, 2.1 kgf/cm²)] through the filter element from the air cleaner case side.

CAUTION - Cleaning the Engine Air Filter

NEVER brush off dirt. Brushing will force dirt into the fibers and cause poor performance in your air filter. Replace the paper filter element if it is excessively dirty.

3. Clean foam element in warm, soapy water or nonflammable solvent. Rinse and dry thoroughly. Dip the element in clean engine oil and completely squeeze out the excess oil from the element before installing.

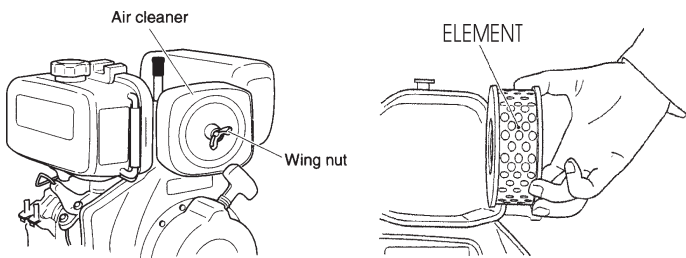

Figure 19. Engine Air Filter

Checking and the V-Belt

After 200 hours of operation, remove the belt cover to check the V-belt tension (Figure 20).

1. Remove the belt cover.
2. Tension is proper if the belt bends about 10 mm when depressed strongly with finger between shafts. Loose or worn V-belts reduces power transmission efficiency, causing weak compaction and reduces the life of the belt itself.

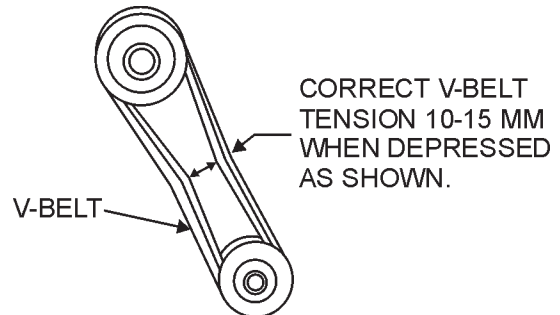

Figure 20. Checking V-belt Tension

CAUTION - Checking and Replacing the V-Belt

NEVER attempt to check the V-belt with the engine running. Severe injury can occur if your hand gets caught between the V-belt and the clutch. Always use safety gloves.



Replacing the V-belt

1. Remove the V-belt cover (Figure 21).
2. Using cutters, simply cut the worn or defective V-belt and discard.
3. Place one end of the new V-belt onto the upper pulley (clutch side).
4. Place a 19 mm offset wrench or the like onto the lower vibrator pulley fastening bolt.
5. Place the other end of the V-belt onto lower vibrator pulley. Rotate offset wrench clockwise so that the V-belt moves onto the lower vibrator pulley.

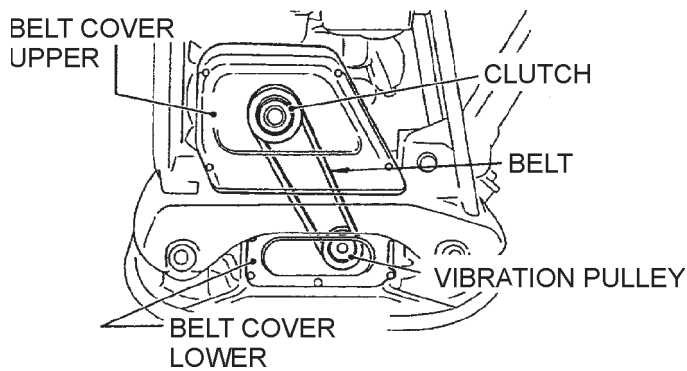

Figure 21. V-Belt Check

Replacing Hydraulic Oil

CAUTION - Vibrator Oil Check

Make sure hydraulic oil in hand pump is at a normal safe operating level. **DO NOT** over fill. Over filling (excessive oil) will cause excess oil to blow out of breather plug.

Check hydraulic oil in every 100 hours of operation. With handle bar positioned vertically (storage position), remove breather plug (Figure 1) off the top of hydraulic pump and check for proper oil level.

Replace hydraulic oil after first 200 hours and in every 1,000 hours of operation.

1. After removing plug cap of hand pump (Figure 10), remove plug of breather (24 mm wrench) and disconnect vibrator side of hydraulic hose (Figure 22) at vibrator cylinder. With travel lever placed in the **FORWARD** position, drain hydraulic oil in the pump.

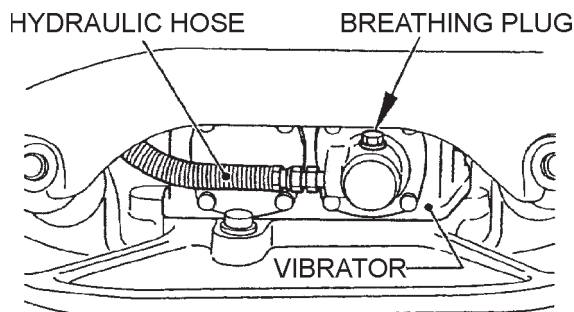

Figure 22. Hydraulic Hose/Breather Plug

2. After draining, reconnect the hydraulic hose to vibrator.
3. Fill oil through breather hole of hand pump. (Capacity: About 300 cc). Use **Shell Tellus Oil #46** or equivalent
4. Removing breather plug at vibrator cylinder causes oil to flow out of breather hole in a while. When aeration disappears, replace the plug and tighten securely.
5. Replace breather plug of hand pump and fit the plug cap. After making sure that oil in pump is at proper level, replace the breather plug.

Checking and Replacing the Clutch

Checking the Clutch

1. With belt cover removed, visually check outer drum of the clutch for seizure and "V" groove for wear or damage.
2. Clean the "V" groove as necessary.
3. Check the clutch lining and shoe for signs of wear. If the shoe is worn, replace the clutch to prevent deficient power transmission and slippage.

Replacing the Clutch

1. Place a 19 mm offset wrench or the like onto the lower vibrator pulley fastening bolt.
2. While pulling back hard on the V-belt near the lower vibrating pulley, rotate offset wrench clockwise so that the V-belt slips off the lower vibrator pulley. Set V-belt aside.
3. Remove bolt at engine power output by giving a shock to an engaged wrench (e.g. tapping with hammer) and rotate the bolt counterclockwise.
4. Remove clutch with a pulley extractor.
5. To install a new clutch, reverse steps 1-4.

MVH-150D2 — ENGINE TROUBLESHOOTING

Practically all breakdowns can be prevented by proper handling and maintenance inspections, but in the event of a breakdown, please take remedial action following the diagnosis based on the Engine Troubleshooting Table (Table 8) information shown below and on the following page. If the problem cannot be remedied, please leave the unit as it is and consult Multiquip's business office or service plant.

TABLE 8. ENGINE TROUBLESHOOTING		
SYMPTOM	POSSIBLE PROBLEM	SOLUTION
Engine will not start or start is delayed, although engine can be turned over.	Speed control lever is in "STOP" position?	Set speed control lever to "START" position.
	No fuel reaching injection pump?	Add fuel. Check entire fuel system.
	Defective fuel pump?	Replace fuel pump.
	Fuel filter clogged?	Replace fuel filter and clean tank.
	Faulty fuel supply line?	Replace or repair fuel line.
	Compression too low?	Check piston, cylinder and valves. Adjust or repair per engine repair manual.
	Fuel injector not working correctly?	Repair or replace injector in accordance with engine repair manual.
	Oil pressure too low?	Check engine oil pressure.
	Low starting temperature limit exceeded	Comply with cold starting instructions and proper oil viscosity.
At low temperatures engine will not start.	Fuel separates has inadequate resistance to low temperatures?	Check whether clear (not turbid) fuel emerges from the fuel line (detach from injection pump). If the fuel is turbid or separated, warm up the engine or drain the complete fuel supply system. Refuel with winter grade diesel fuel.
	Engine oil too thick?	Refill engine crankcase with correct type of oil for winter environment.
Engine fires but stops soon as starter is switched off.	Throttle lever in STOP position?	Reposition throttle lever to RUN position.
	Fuel filter blocked?	Replace fuel filter.
	Fuel supply blocked?	Check the entire fuel system.
Engine stops by itself during normal operation.	Fuel tank empty?	Add fuel.
	Fuel filter blocked?	Replace fuel filter.
Low engine power, output and speed.	Fuel tank empty?	Fill with No.2 diesel fuel.
	Fuel filter clogged?	Replace fuel filter.
	Fuel tank venting is inadequate?	Ensure that tank is adequately vented.
	Speed control lever does not remain in selected position?	See engine manual for corrective action.
	Engine oil level too full?	Correct engine oil level?
Low engine power output and low speed, black exhaust smoke.	Air filter blocked?	Clean or replace air filter.
	Incorrect valve clearances?	Adjust valves per engine specification.
	Malfunction at injector?	See engine manual.

MVH-150D2 — PLATE COMPACTOR TROUBLESHOOTING

Practically all breakdowns can be prevented by proper handling and maintenance inspections, but in the event of a breakdown, please take remedial action following the diagnosis based on the Compactor Troubleshooting Table (Table 9) information shown below. If the problem cannot be remedied, please leave the unit as it is and consult Multiquip's business office or service plant.

TABLE 9. PLATE COMPACTOR TROUBLESHOOTING		
SYMPTOM	POSSIBLE CAUSE	SOLUTION
Travel speed too low, and vibration is weak.	Engine speed too low?	Set engine speed to correct RPM.
	Clutch slips?	Check or replace clutch.
	V-belt slips?	Adjust or replace V-belt.
	Excessive oil in vibrator?	Drain excess oil and fill to proper level.
	Malfunction in vibrator housing?	Check eccentric, gears and counter weights.
Travels forward or reverse, but impossible to switch direction.	Directional components defective?	Check all directional components
	Reversing lever adjustment?	Adjust or repair reversing lever.
	Hydraulic oil hose broken?	Repair or replace hydraulic oil hose.
	Aeration in hydraulic oil for reversing system?	Bleed hydraulic oil system.
	Check valve in hand pump clogged with dust?	Clean or replace hand pump check valve.
	Piston or bearing in cylinder (vibrator assy.) is defective?	If worn, replace cylinder piston or bearing.
Does not travel either forward or reverse.	V-belt slips?	Replace V-belt.
	Clutch slips?	Check clutch springs and shoes.
	Vibrator locked?	Check vibrator housing (eccentric, gears and counterweights)
	Piston or bearing in cylinder defective?	If worn, replace cylinder piston or bearing.
Travel lever operating resistance great.	Air in hydraulic line?	Bleed hydraulic oil system.
	Piston or bearing in cylinder defective?	If worn, replace cylinder piston or bearing.

MVH-150D2 — EXPLANATION OF CODE IN REMARKS COLUMN

The following section explains the different symbols and remarks used in the Parts section of this manual. Use the help numbers found on the back page of the manual if there are any questions.

The contents and part numbers listed in the parts section are subject to change **without notice**. Multiquip does not guarantee the availability of the parts listed.

Sample Parts List:

NO.	PART NO.	PART NAME	QTY.	REMARKS
1	12345	BOLT	1	INCLUDES ITEMS W/*
2*		WASHER, 1/4 IN.		NOT SOLD SEPARATELY
2*	12347	WASHER, 3/8 IN.	1	MQ-45T ONLY
3	12348	HOSE	A/R ..	MAKE LOCALLY
4	12349	BEARING	1	S/N 2345B AND ABOVE

NO. Column

Unique Symbols - All items with same unique symbol (*, #, +, %, or >) in the number column belong to the same assembly or kit, which is indicated by a note in the "Remarks" column.

Duplicate Item Numbers - Duplicate numbers indicate multiple part numbers are in effect for the same general item, such as different size saw blade guards in use or a part that has been updated on newer versions of the same machine.

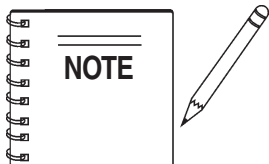

When ordering a part that has more than one item number listed, check the remarks column for help in determining the proper part to order.

PART NO. Column

Numbers Used - Part numbers can be indicated by a number, a blank entry, or TBD.

TBD (To Be Determined) is generally used to show a part that has not been assigned a formal part number at time of publication.

A blank entry generally indicates that the item is not sold separately or is not sold by Multiquip. Other entries will be clarified in the "Remarks" Column.

QTY. Column

Numbers Used - Item quantity can be indicated by a number, a blank entry, or A/R.

A/R (As Required) is generally used for hoses or other parts that are sold in bulk and cut to length.

A blank entry generally indicates that the item is not sold separately. Other entries will be clarified in the "Remarks" Column.

REMARKS Column

Some of the most common notes found in the "Remarks" Column are listed below. Other additional notes needed to describe the item can also be shown.

Assembly/Kit - All items on the parts list with the same unique symbol will be included when this item is purchased.

Indicated by:
"INCLUDES ITEMS W/(unique symbol)"

Serial Number Break - Used to list an effective serial number range where a particular part is used.

Indicated by:
"S/N XXXXX AND BELOW"
"S/N XXXX AND ABOVE"
"S/N XXXX TO S/N XXX"

Specific Model Number Use - Indicates that the part is used only with the specific model number or model number variant listed. It can also be used to show a part is NOT used on a specific model or model number variant.

Indicated by:
"XXXXX ONLY"
"NOT USED ON XXXX"

"Make/Obtain Locally" - Indicates that the part can be purchased at any hardware shop or made out of available items. Examples include battery cables, shims, and certain washers and nuts.

"Not Sold Separately" - Indicates that an item cannot be purchased as a separate item and is either part of an assembly/kit that can be purchased, or is not available for sale through Multiquip.

MQ MIKASA MVH-150D2 PLATE COMPACTOR W/YANMAR L48V6 DIESEL ENGINE

1 to 3 Units

<u>Qty.</u>	<u>P/N</u>	<u>Description</u>
3	070100352	V-BELT A-35 (BLUE)
2	956100059	THROTTLE WIRE
3	11465012590 ...	ELEMENT, A/C W/PRE-FILTER
1	11429955040 ...	CAP, FUEL TANK
1	11429976630 ...	ROPE, RECOIL STARTER
2	11429935110 ...	LUB. OIL FILTER COMPLETE
2	11425055121 ...	FILTER, FUEL STAINER
1	11429955100 ...	FILTER, FUEL OIL
4	939010130	SHOCK ABSORBER

MVH-150D2 — NAMEPLATE AND DECALS

NAME PLATE AND DECAL ASSY.

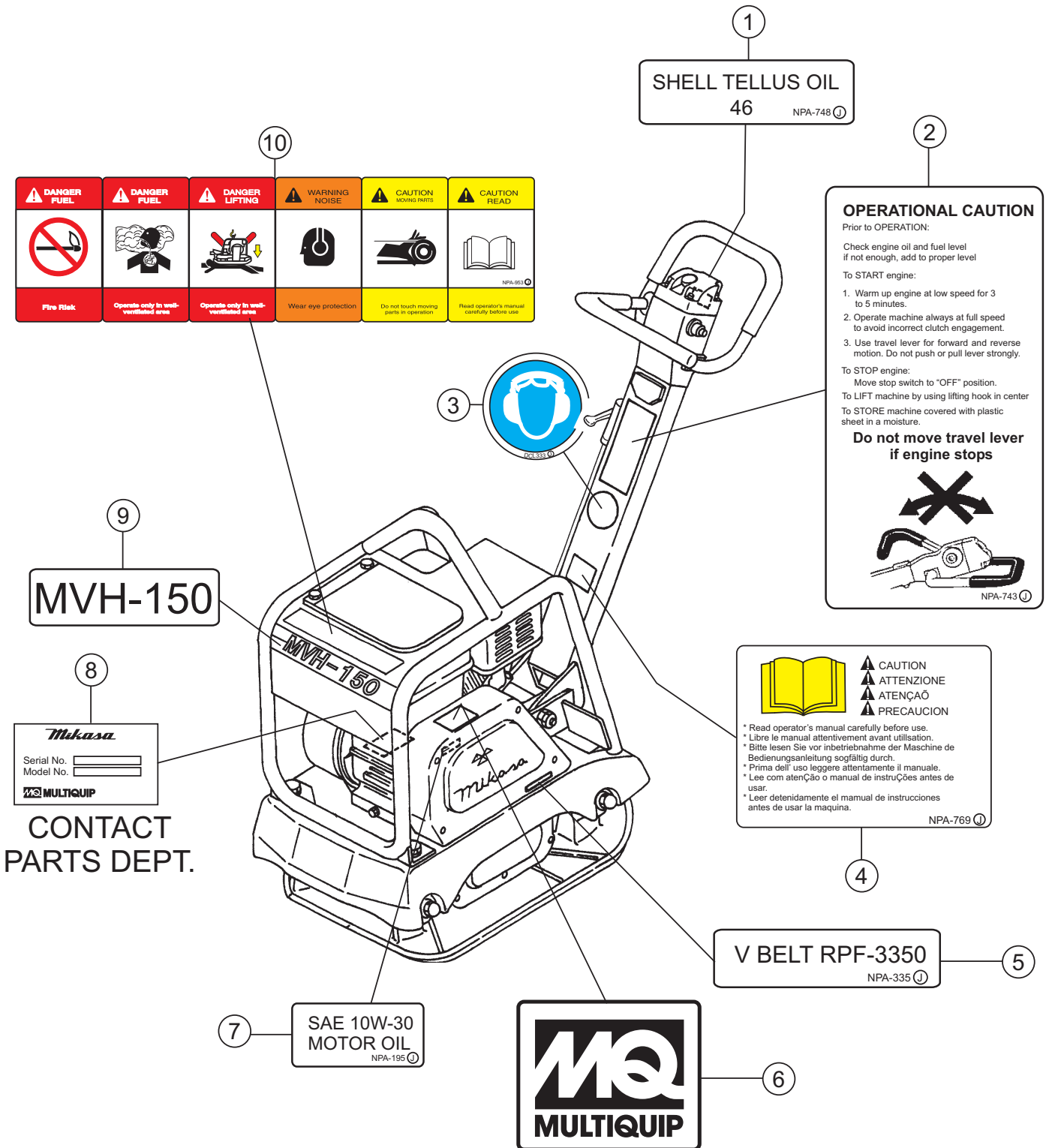

MVH-150D2 — NAMEPLATE AND DECALS

NAME PLATES ASSY.

<u>NO.</u>	<u>PART NO.</u>	<u>PART NAME</u>	<u>QTY.</u>	<u>REMARKS</u>
1	920207480	DECAL: SHELL TELLUS OIL 46	1	NPA-748
2	920207430	DECAL: CAUTION	1	NPA-743
3	920203330	EAR PROTECTION LABEL	1	NPA-333
4	920207690	DECAL: CAUTION, MANUAL	1	NPA-769
5	920207670	DECAL: V-BELT RPF-3350	1	NPA-335
6	920201580	DECAL: MQ LOGO	1	NPA-158
7	920201950	DECAL: OIL SAE 10W-30	1	NPA-195
8		DECAL: NAME PLATE	1	CONTACT MQ PARTS
9	920207660	DECAL: MODEL/MVH150	1	
10	920209530	DECAL: CAUTION/ COMBINATION	1	

MVH-150D2 — VIBRATING PLATE ASSY.

VIBRATING PLATE

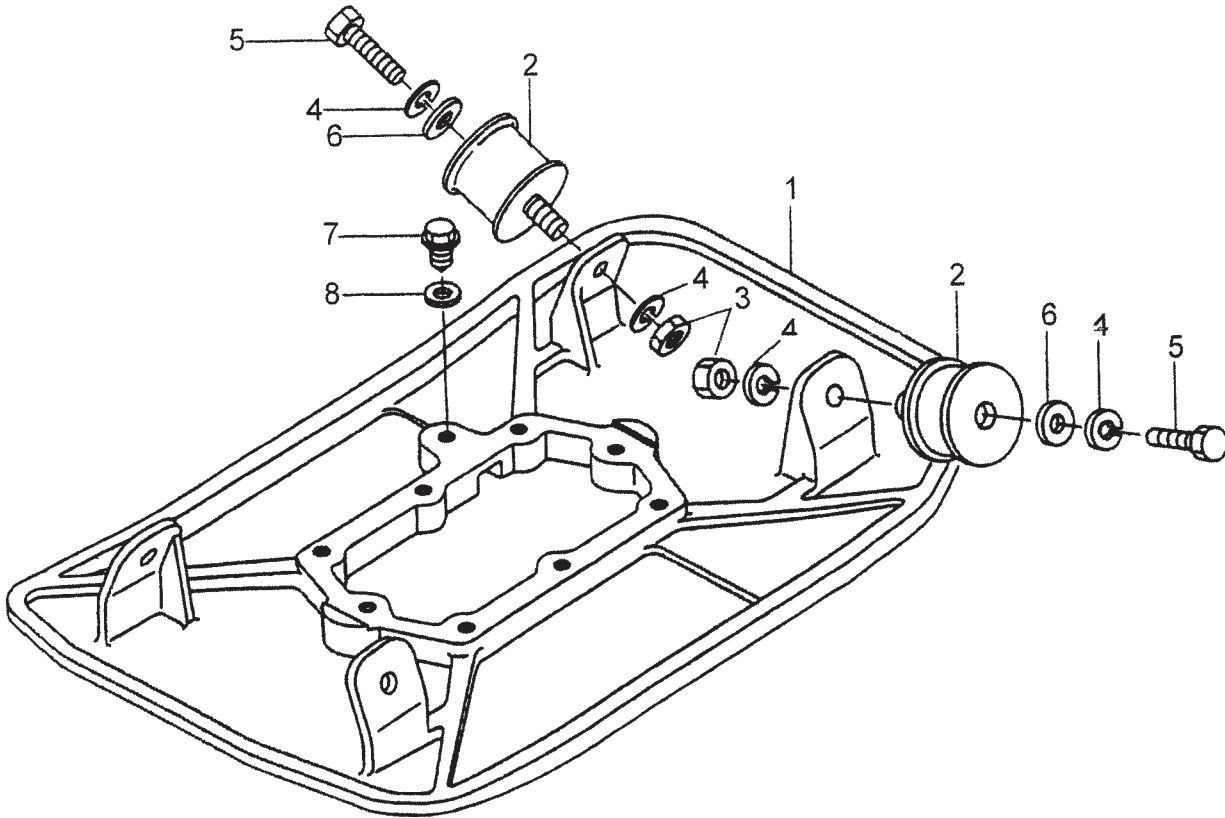

MVH-150D2 — VIBRATING PLATE ASSY.

VIBRATING PLATE

<u>NO.</u>	<u>PART NO.</u>	<u>PART NAME</u>	<u>QTY.</u>	<u>REMARKS</u>
1	459115390	VIBRATING PLATE	1	
2	939010130	SHOCK ABSORBER MED-70S	4	
3	020312100	NUT M12	4	
4	030212300	WASHER, LOCK M12	8	
5	001221230	BOLT 12 X 30 T	4	
6	952405600	WASHER 12.5 X 35 4.5	4	
7	460449160	OIL GAUGE	1	
8	953405260	PACKING 1/4, CU	1	

MVH-150D2 — BODY ASSY.

BODY ASSY.

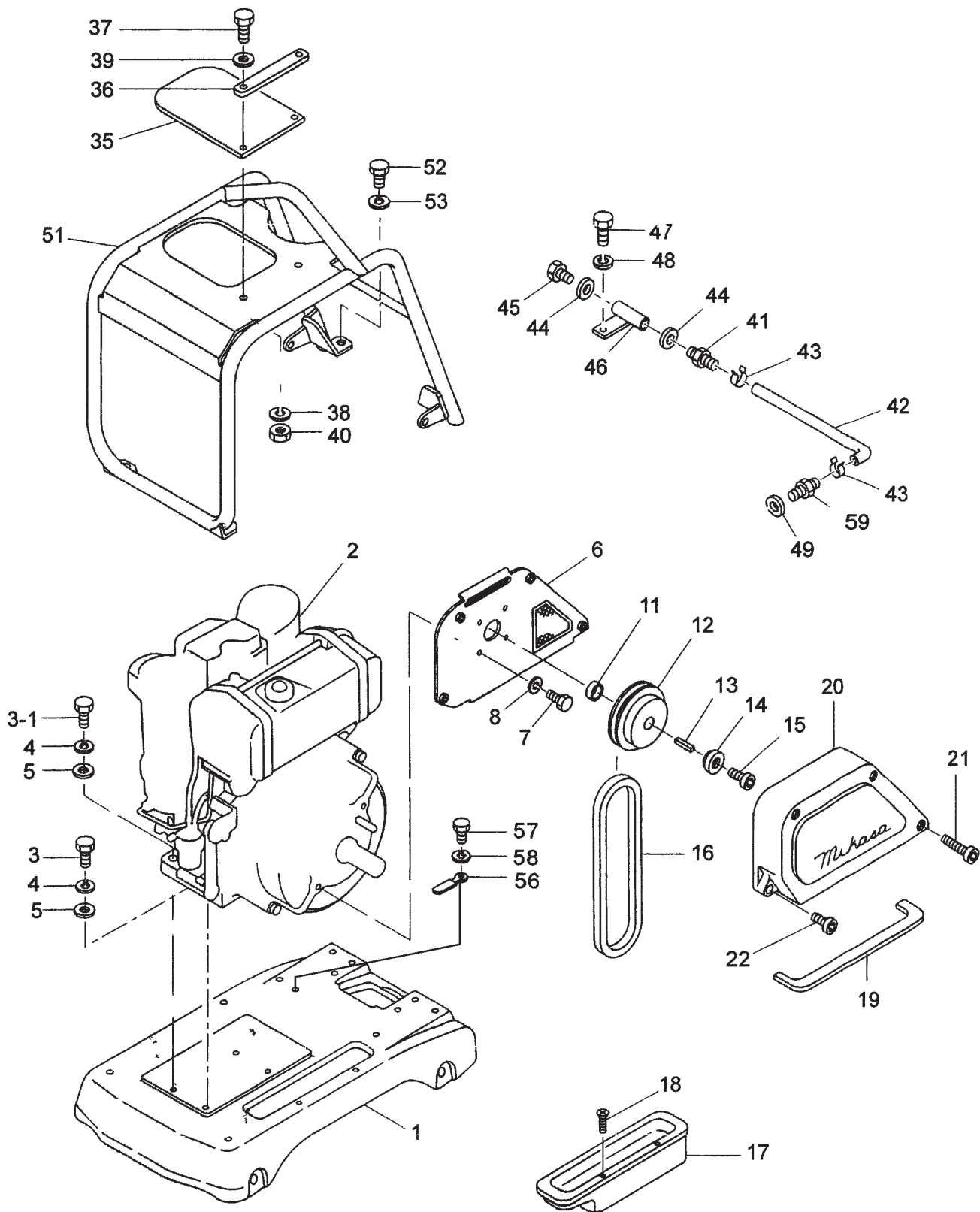

BODY ASSY.

<u>NO.</u>	<u>PART NO.</u>	<u>PART NAME</u>	<u>QTY.</u>	<u>REMARKS</u>
1	459116670	BASE	1	
2	914410024	ENGINE ASSY. L48V6F3R4AAW4	1	
3	001221040	BOLT 10X40 T	3	
3-1	001221035	BOLT 10X35 T	1	
4	030210250	WASHER, LOCK M10	4	
5	031110160	WASHER, FLAT M10	4	
6	459216380	BELT COVER PLATE	1	
7	001220820	BOLT 8X20 T	4	
8	030208200	WASHER, LOCK M8	4	
11	458451370	SPACER 202512	1	
12	458337770	CLUTCH ASSY. A1-124-20	1	
13	951406780	KEY 5X5X30 RR	1	
14	458451380	CLUTCH WASHER	1	
15	001520825	SOCKET HEAD BOLT 8X25 T	1	
16	070100352	V-BELT A-35 BLUE/ RPF3350	1	
17	459214530	DUST COVER	1	
18	092006010	FLAT HEAD SCREW 6X10	2	
19	459338190	SPONGE, DUST COVER	1	
20	459115420	BELT COVER , UPPER	1	
21	001520852	SOCKET HEAD BOLT 8X60 T	3	
22	001520852	SOCKET HEAD BOLT 8X20 T	1	
35	458450830	RUBBER COVER	1	
36	458450810	PLATE, RUBBER COVER	1	
37	001220825	BOLT 8X25 T	2	
38	030208200	WASHER, LOCK M8	2	
39	031108160	WASHER, FLAT M8	2	
40	022710809	NYLON NUT M8	2	
41	2556390111	UNION	1	
42	2556380103	DRAIN HOSE	1	
43	0091720000	HOSE CLAMP	2	
44	0211140020	GASET	2	
45	0401140030	PLUG	1	
46	4594154460	JOINT BLOCK	1	
47	001220820	BOLT 8X20 T	1	
48	030208200	SW M8	1	
49	22190160002	SEAL WASHER 16S	1	
51	459116680	GUARD FRAME, L48	1	
52	001221225	BOLT 12X25 T	4	
53	030212300	WASHER, LOCK M12	4	
56	954406820	CORD CLAMP	1	
57	001220610	BOLT 6X10 T	1	
58	030206150	WASHER, LOCK M6	1	
59	459455560	UNION, OIL DRAIN L48	1	

MVH-150D2 — VIBRATOR ASSY.

VIBRATOR ASSY.

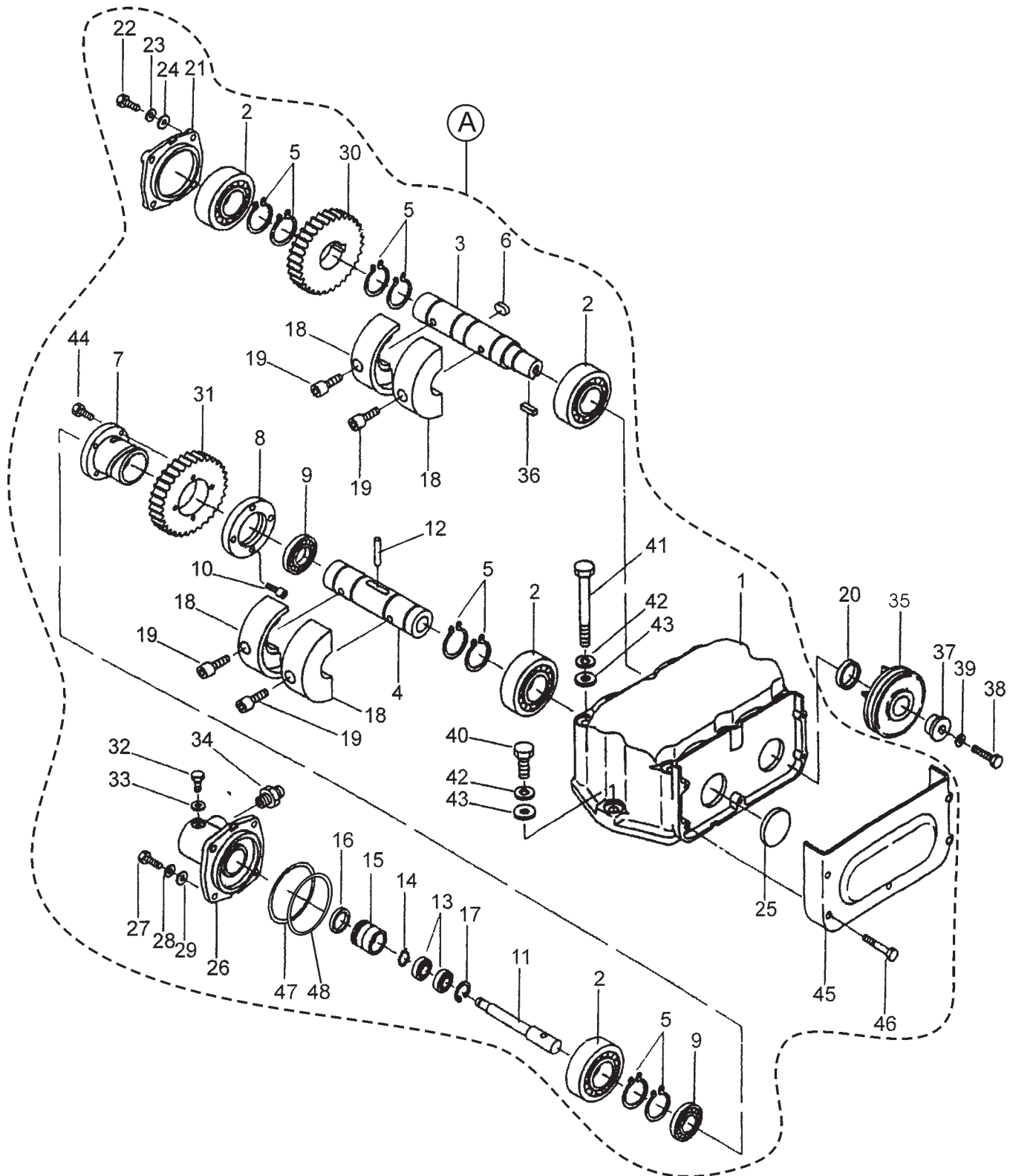

MVH-150D2 — VIBRATOR ASSY.

VIBRATOR ASSY.

<u>NO.</u>	<u>PART NO.</u>	<u>PART NAME</u>	<u>QTY.</u>	<u>REMARKS</u>
A	459910011	VIBRATOR ASSY.	1	INCLUDES ITEMS W/*
1*	458115150	VIBRATING CASE	1	
2*	047920090	ROLLER BEARING NJ307MC4	4	
3*	458337700	ROTARY SHAFT, DRIVE	1	
4*	458342580	ROTARY SHAFT, DRIVEN	1	
5*	080200350	STOP RING S-35	8	
6*	951405460	KEY 10X8X19 RR	1	
9*	040306907	BEARING 6907C3	4	
11*	458337730	PISTON ROD	1	
12*	025508050	PIN 8X50	1	
13*	042506000	BEARING 6000ZZSG	2	
14*	080200100	STOP RING S-10	1	
15*	455435051	PISTON, 22.4D	1	
16*	455010070	PACKING USH-22.4X30X5	1	
17*	080100260	STOP RING R-26	1	
18*	459451850	ECCENTRIC ROTATOR	4	
19*	009120306	SOCKET HEAD BOLT 10X30 T	4	
20	060202040	OIL SEAL SC-28458	1	
21*	458337740	BEARING COVER	1	
22*	001220820	BOLT 8X20 T	4	
23*	030208200	WASHER, LOCK M8	4	
24*	031108160	WASHER, FLAT M8	4	
25*	953405580	SEAL CAP SC-458	1	
26*	458214370	CYLINDER	1	
27*	001220820	BOLT 8X20 T	4	
28*	030208200	WASHER, LOCK M8	4	
29*	031108160	WASHER, FLAT M8	4	
30*	460333000	GEAR, DRIVE	1	
31*	458342590	GEAR, DRIVEN	1	
32*	001200812	BOLT 8X12	1	
33*	953404600	COPPER PACKING 8X16X2	1	
34*	954010020	CONNECTOR PT, PF1/4	1	
35	459341310	PULLEY 90D W/FAN	1	
36*	951400990	KEY 7X7X20	1	
37	459452100	WASHER 9X24-30X17	1	
38	001220835	BOLT 8X35 T	1	
39	030208200	WASHER, LOCK M8	1	
40*	001221235	BOLT 12X35 T	2	
41*	001221264	BOLT 12X120 T	6	
42*	030212300	WASHER	8	
43*	031112230	WASHER	8	
45*	459214510	BELT COVER LOWER	1	
46*	001520645	SOCKET HEAD 6X45 T	5	
47*	952406170	SHIM 70 80 0 1T	1	
48*	952406180	SHIM 70 80 0 2T	1	

MVH-150D2 — CONTROL ASSY.

CONTROL ASSY.

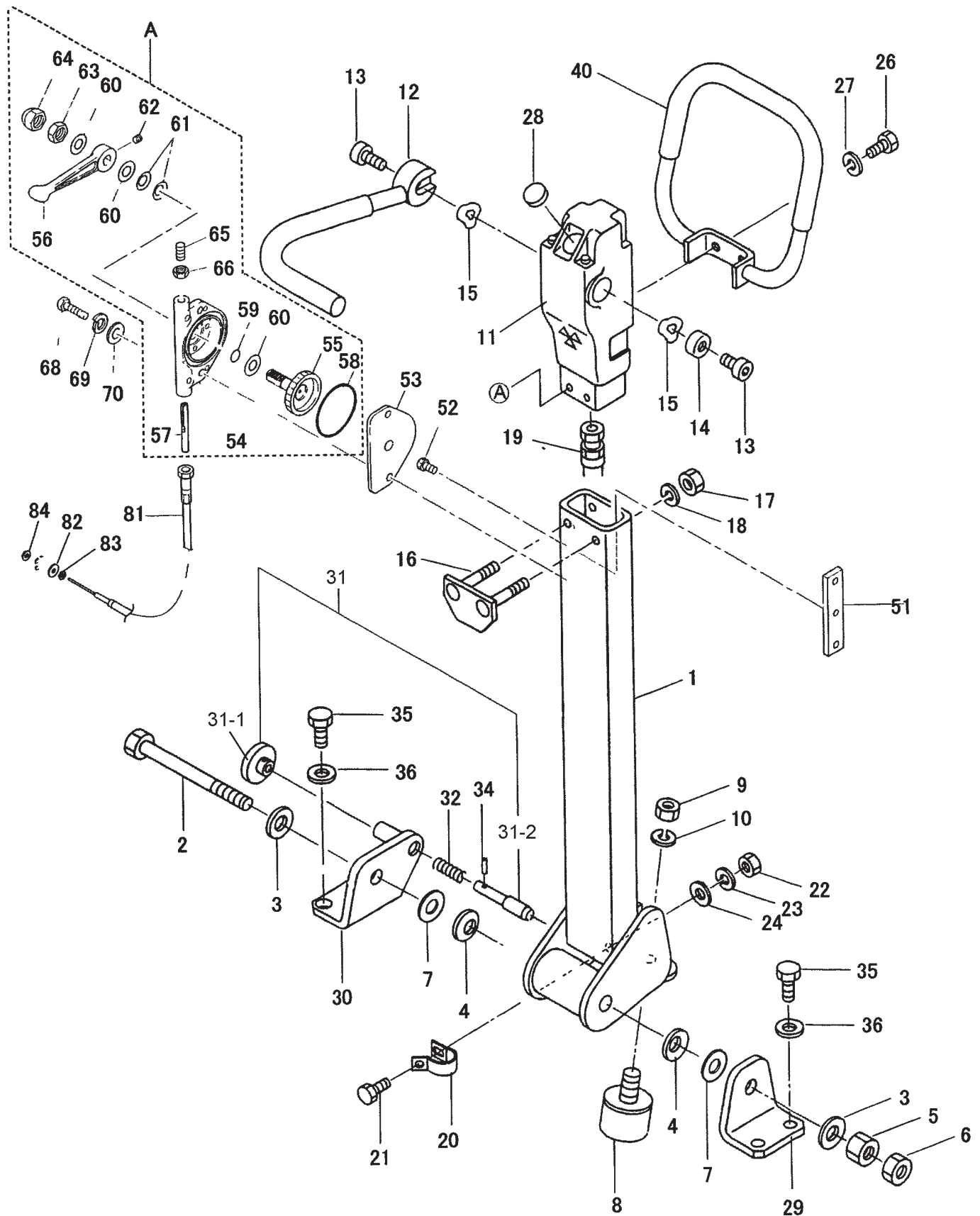

MVH-150D2 — CONTROL ASSY.

CONTROL ASSY.

<u>NO.</u>	<u>PART NO.</u>	<u>PART NAME</u>	<u>QTY.</u>	<u>REMARKS</u>
1	459115451	HANDLE	1	
2	001221669	BOLT, 16X145 T	1	
3	031116260	WASHER, FLAT, M16	2	
4	032216350	CONCIAL SPRING WASHER M16	2	
5	020316130	NUT, M16	1	
6	020416100	NUT, M16 H=10	1	
7	458450660	WASHER, 16.4-35-0.6	1	
8	939010010	SHOCK ABSORBER, STOPPER 45	1	
9	020310080	NUT, M10	1	
10	030210250	WASHER, LOCK, M10	1	
11	458338001	PUMP, ASSY.	1	
12	459337960	TRAVEL LEVER	1	
13	001520820	SOCKET, HEAD BOLT 8X20 T	2	
14	458451420	COLLAR	1	
15	033910030	WAVE WASHER, 15.5X20X0.3	4	
16	458337480	PUMP HOLDER	1	
17	022710809	NYLON NUT M8	2	
18	030208200	WASHER, LOCK M8	2	
19	459452060	OIL HOSE, 940L	1	
20	954404230	CLAMP, SA120-18	1	
21	001220625	BOLT, 6X25 T	1	
22	020306050	NUT, M6	1	
23	030206150	WASHER, LOCK M6	1	
24	031106100	WASHER, FLAT M6	1	
26	001220820	BOLT, 8X20 T	2	
27	030208200	WASHER, LOCK M8	2	
28	458451630	BRATHER CAP	1	
29	459338030	HANDLE BRACKET, L	1	
30	459338041	HANDLE BRACKET, R	1	
31	458910030	STOPPER & GRIP SET	1	INCLUDES ITEMS W/#
31-1#		STOPPER	1	NOT SOLD SEPARATELY
31-2#		GRIP	1	NOT SOLD SEPARATELY
32	458450880	SPRING, 1.2-10-29	1	
34	025402516	SPRING PIN, 2.5X16	1	
35	001221230	BOLT, 12X30 T	4	
36	030212300	WASHER, LOCK M12	4	
40	458314400	HANDLE GRIP, EXP	1	
51	463455960	THROTTLE NUT	1	
52	001520510	SOCKET, HEAD BOLT 5X10 T	1	
53	463455950	SPACER, THROTTLE	1	

MVH-150D2 — CONTROL ASSY.

CONTROL ASSY.

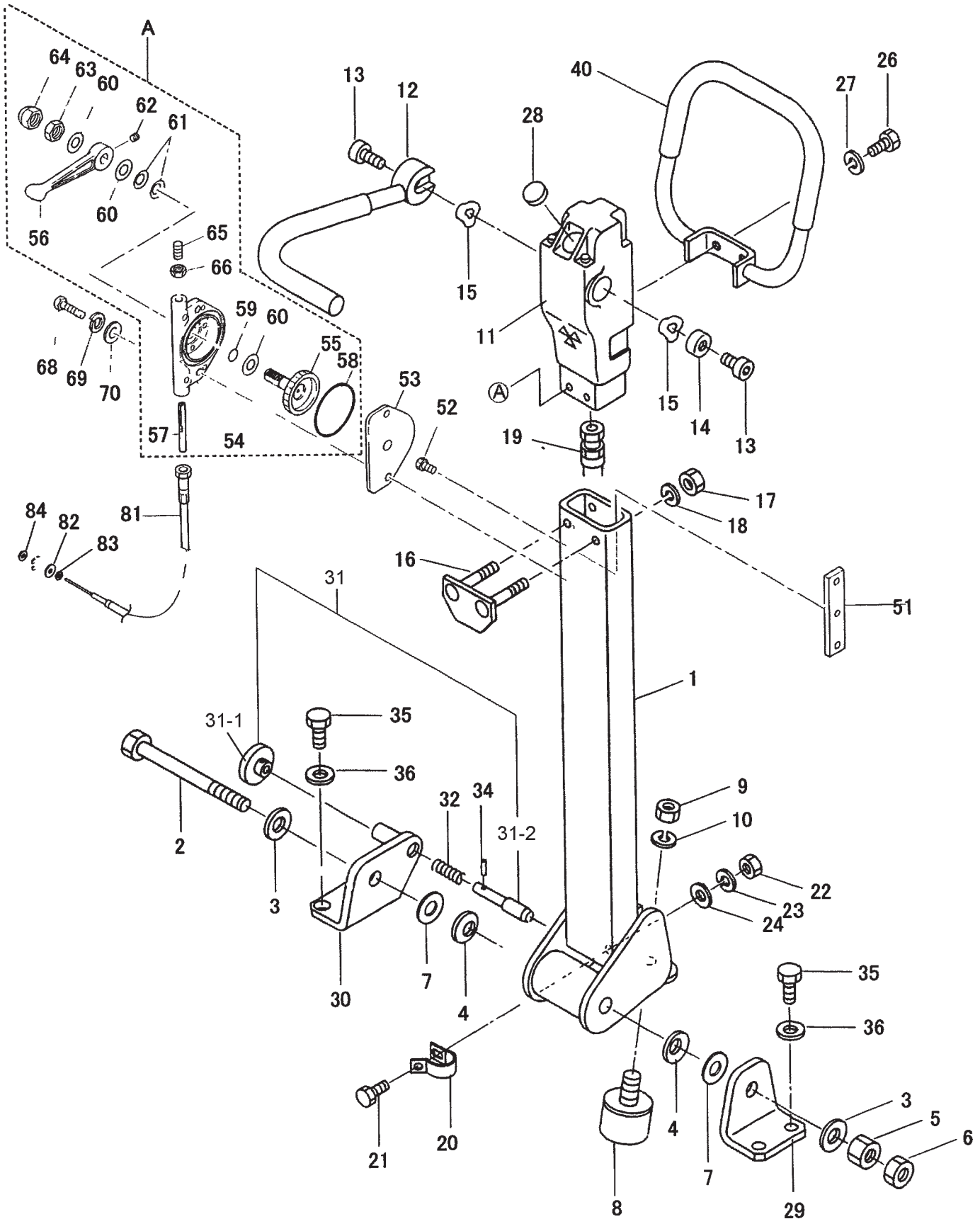

MVH-150D2 — CONTROL ASSY.

CONTROL ASSY.

<u>NO.</u>	<u>PART NO.</u>	<u>PART NAME</u>	<u>QTY.</u>	<u>REMARKS</u>
A	362910060	THROTTLE LEVER ASSY.....	1	INCLUDES ITEMS W/*
54*	342341550	THROTTLE BODY	1	
55*	362910090	THROTTLE GEAR	1	
56*	362455630	THROTTLE LEVER	1	
57*	362455620	SLIDER	1	
58*	050100450	O-RING, G45	1	
59*	050200100	O-RING, P10	1	
60*	031110160	WASHER, FLAT M10	3	
61*	032110180	CONICAL SPRING WASHER M10	2	
62*	096206006	SOCKET HEAD SCREW 6X6	1	
63*	020410060	NUT M10 H=6	1	
64*	1022131008	CAP NUT M10	1	
65*	096208020	SOCKET HEAD SCREW 8X20	1	
66*	020408050	NUT M8, H=5	1	
68	001220625	BOLT 6X25 T	2	
69	030206150	WASHER, LOCK	2	
70	031106100	WASHER, FLAT	2	
81	956100059	THROTTLE WIRE	1	
82	16067066350	WASHER/THROTTLE	1	
83	26756060002	LOCK NUT M6 PLATED	1	
84	26366060002	NUT M6	1	

MVH-150D2 — HAND PUMP ASSY.

HANDLE PUMP ASSY.

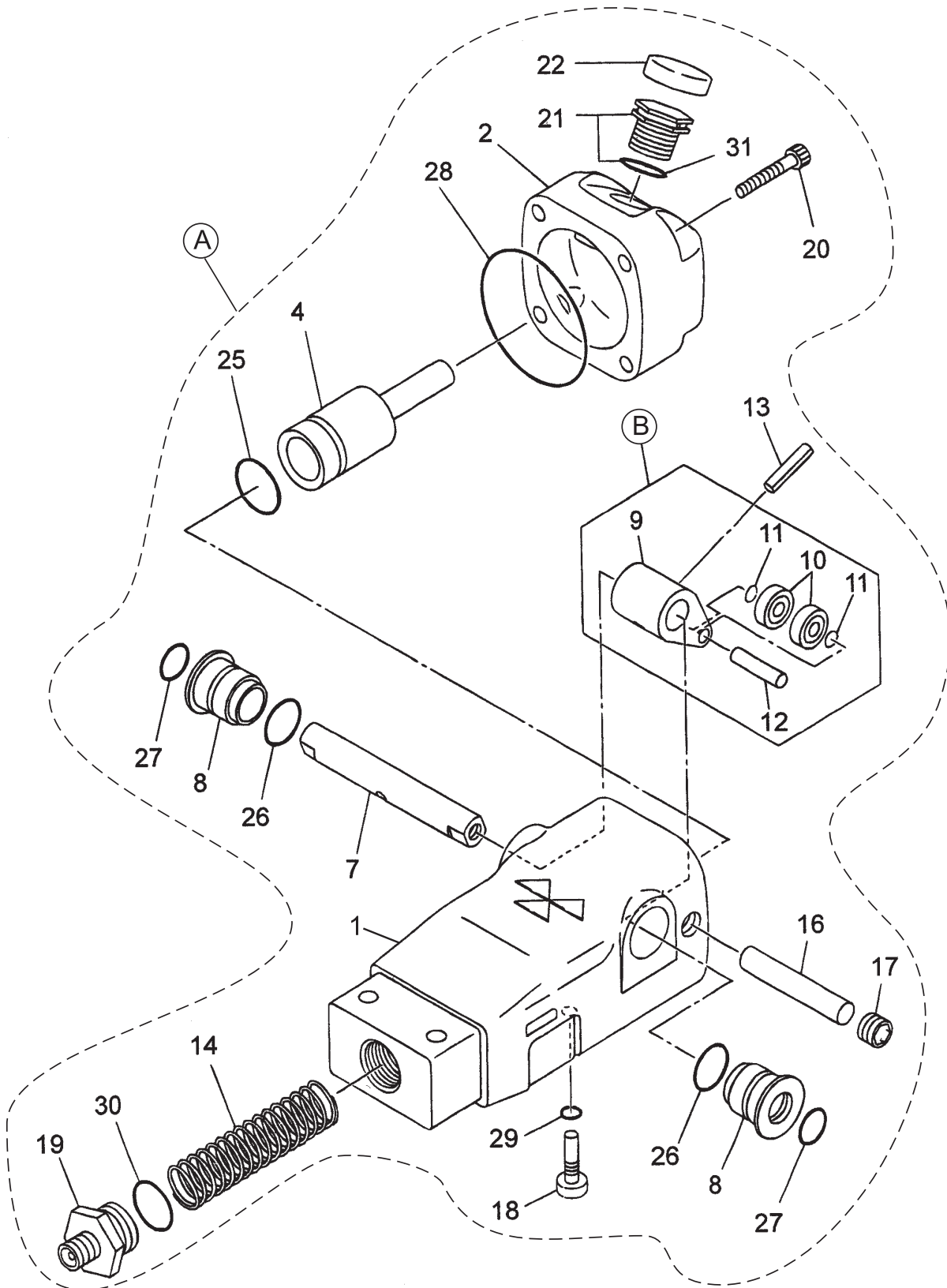

MVH-150D2 — HAND PUMP ASSY.

HANDLE PUMP ASSY.

<u>NO.</u>	<u>PART NO.</u>	<u>PART NAME</u>	<u>QTY.</u>	<u>REMARKS</u>
A	458338001	PUMP ASSY.	1	INCLUDES ITEMS W/*
B	458310150	CAM COMP, PUMP	1	INCLUDES ITEMS W/%
1*	458010160	PUMP BODY	1	
2*	458010100	COVER, HAND PUMP	1	
4*	458010170	PISTON CP, PUMP	1	
7*	458010110	CONTROL SHAFT, PUMP	1	
8*	458010120	BUSH	2	
9*%	458010180	CAM, PUMP	1	
10*%	042500607	BEARING, 607ZZSG	2	
11*%	458010190	SPACER	2	
12*%	458010090	PIN, 7X30	1	
13*	025406025	SPRING, PIN 6X25	1	
14*	458010200	SPRING, PUMP	1	
16*	458010210	STOPPER, PUMP	1	
17*	458010220	PLUG	1	
18*	458010131	STOP PLUG	1	
19*	458010140	HOSE JOINT	1	
20*	001540635	SOCKET, HEAD BOLT 6X35 S	4	
21*	458010080	BREATHER, PUMP	1	INCLUDES ITEMS W/ #
22*	458451630	BREATHER, CAP	1	
25*	050100250	O-RING G-25	1	
26*	050200200	O-RING P-20	2	
27*	050200150	O-RING P-15	2	
28*	050300670	O-RING S-67	1	
29*	050300080	O-RING S-8	1	
30*	050300220	O-RING S-22	1	
31*#	050200180	O-RING P-18	1	

YANMAR L48V6 ENGINE—CYLINDER BLOCK ASSY.

CYLINDER BLOCK ASSY.

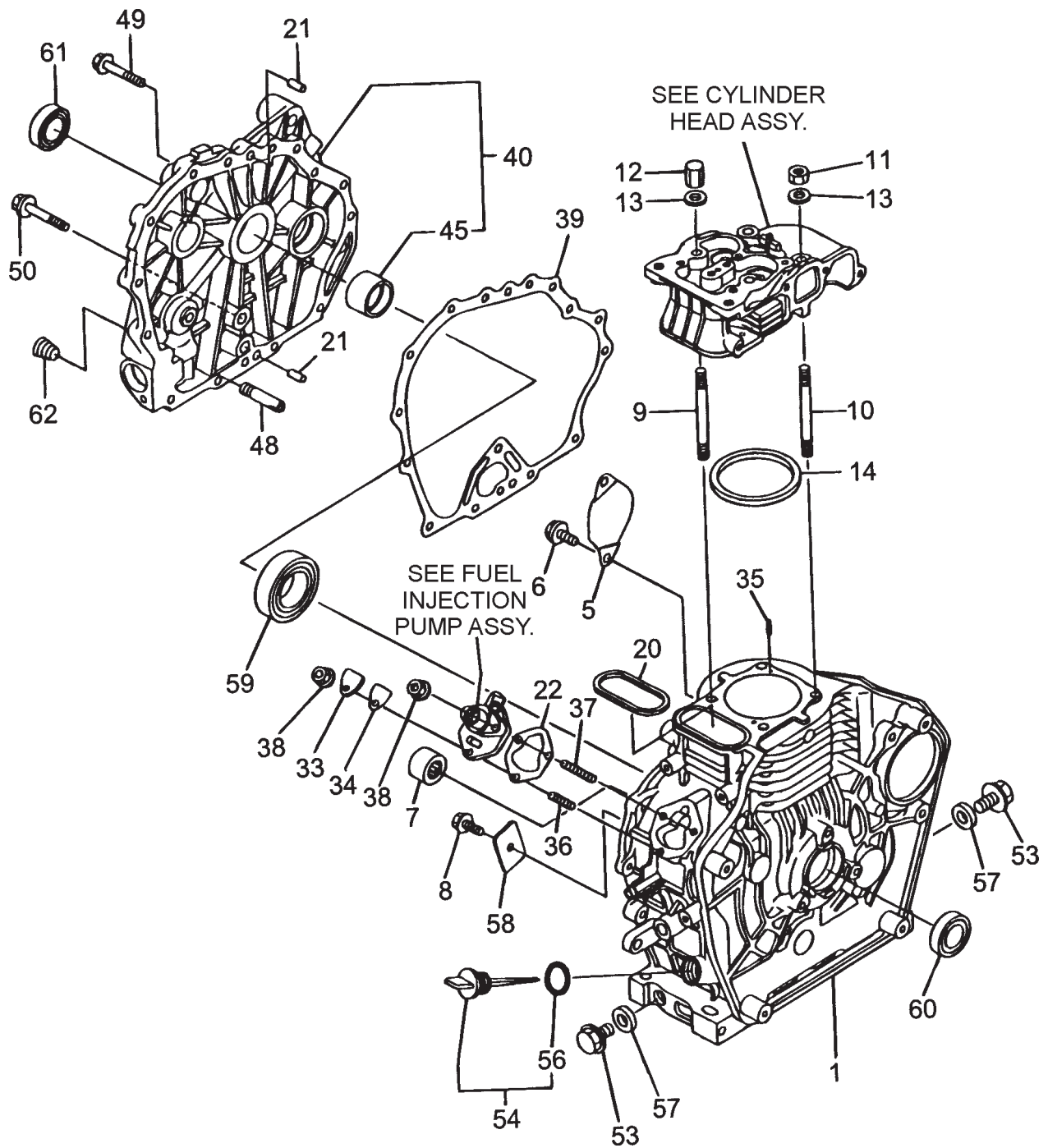

YANMAR L48V6 ENGINE — CYLINDER BLOCK ASSY.

CYLINDER BLOCK ASSY.

<u>NO.</u>	<u>PART NO.</u>	<u>PART NAME</u>	<u>QTY.</u>	<u>REMARKS</u>
1	11429501050	CYLINDER BLOCK ASSY.	1	
5	11439901700	STARTER COVER	1	
6	26106100122	BOLT M10X 12 PLATED	2	
7	24162152112	NEEDLE BEARING	1	
8	26106080122	BOLT M 8X 12 PLATED	1	
9	11429901200	CYLINDER HEAD BOLT A	2	
10	11429901210	CYLINDER HEAD BOLT B	2	
11	11429901220	CYLINDER HEAD NUT A	2	
12	11429901230	CYLINDER HEAD NUT B	2	
13	12495001250	WASHER	4	
14	11429501330	CYLINDER HEAD GASKET ASSY.	1	
20	11429901380	O- RING	1	
21	11429901600	PIN 8X12	2	
22	11429901800	SHIM SET	1	
33	11429901830	COVER, (FO PUMP)	1	
34	11425001841	GASKET	1	
35	22312040080	PIN 4X8 STRAIGHT	2	
36	26226060182	STUD M 6X 18 PLATED	1	
37	26226060222	STUD M 6X 22 PLATED	2	
38	26366060002	NUT M 6	3	
39	11429901410	CRANK CASE GASKET	1	
40	11428401452	CRANK CASE COVER	1	INCLUDES ITEMS W/*
45*	11425002100	MAIN BEARING US=STD.	1	
45	11425002200	BEARING US=0.25, MAIN	1	
45	11425002210	BEARING US=0.50, MAIN	1	
48	11429935150	L.O. INLET PIPE	1	
49	26106060252	BOLT M 6X 25 PLATED	14	
50	26106080352	BOLT M 8X 35 PLATED	1	
53	11429901690	PLUG M16	2	
54	11429901760	CAP, W/LUBE OIL GAUGE	1	INCLUDES ITEMS W/#
56#	11429901950	O- RING	1	
57	22190160002	SEAL WASHER 16S	2	
58	11429902030	RETAINER	1	
59	11425002113	BALL BEARING	1	
60	11429902220	OIL SEAL	1	
61	16021002220	OIL SEAL	1	
62	23876010000	PLUG PT 1/8, SCREW	1	

YANMAR L48V6 ENGINE—CYLINDER HEAD ASSY.

CYLINDER HEAD ASSY.

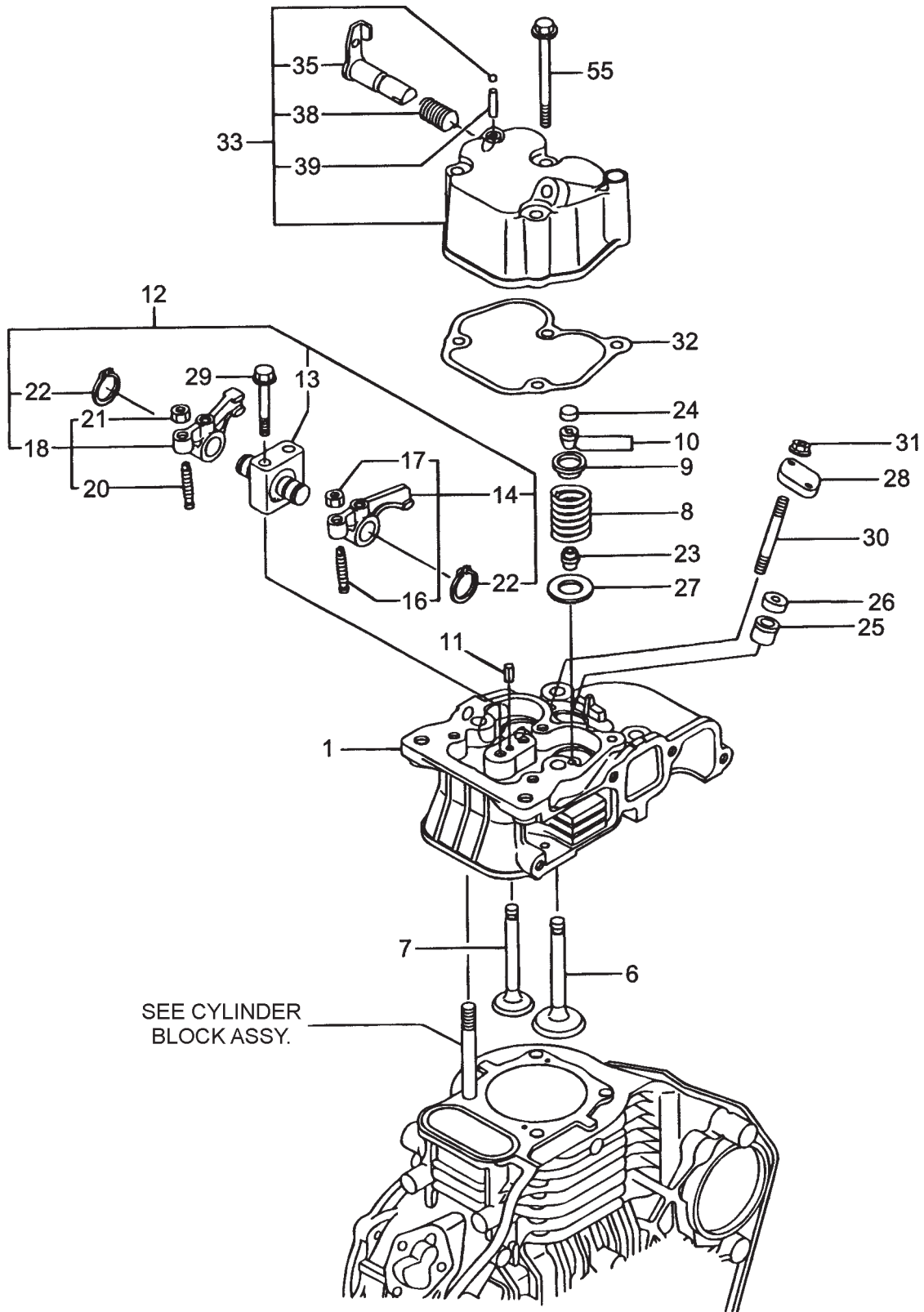

YANMAR L48V6—CYLINDER HEAD ASSY.

CYLINDER HEAD ASSY.

<u>NO.</u>	<u>PART NO.</u>	<u>PART NAME</u>	<u>QTY.</u>	<u>REMARKS</u>
1	11477111020	CYLINDER HEAD	1	
6	11477111100	SUCTION VALVE	1	
7	11477111110	EXHAUST VALVE	1	
8	11429911120	VALVE SPRING	2	
9	1142511180	SPRING RETAINER	2	
10	27310055001	COTTER	2	
11	22351040008	SPRING PIN 4X8	1	
12	11477111250	ARM SUPPORT CAM	1	INCLUDES ITEMS W/*
13*	11477111260	ROCKER ARM SUPPORT	1	
14*	11477111650	INTAKE ARM ASSY.	1	INCLUDES ITEMS W/%
16%	11425011240	VALVE ADJUST. SCREW	1	
17%	26856060002	LOCK NUT 6	1	
18*	11477111660	EXHAUST ARM ASSY.	1	INCLUDES ITEMS W/\$
20\$	11425011240	VALVE ADJUST. SCREW	1	
21\$	26856060002	LOCK NUT 6	1	
22*	22242000120	CIR CLIP 12	2	
23	11425011340	VALVE STEM SEAR	2	
24	11926011370	VALVE CAP	2	
25	11477111461	NOZZLE GASKET	1	
26	11429511470	NOZZLE SPACER	1	
27	11429911600	VALVE SPRING WASHER	2	
28	11429911901	NOZZLE RETAINER	1	
29	26106060452	BOLT M 6X45 PLATED	2	
30	11471811910	STUD BOLT M6X65	2	
31	26366060002	NUT M 6	2	
32	11477111310	BONNET GASKET	1	
33	11429511951	BONNET COMPLETE	1	INCLUDES ITEMS W/#
35#	11425003591	SHAFT ASSY. DECOMP.	1	
38#	11429903640	SPRING, DECOMP.	1	
39#	22312030160	PARALLEL PIN 3X16	1	
55	26106060552	BOLT M 6X 55 PLATED	3	

YANMAR L48V6 ENGINE— AIR CLEANER ASSY.

AIR CLEANER

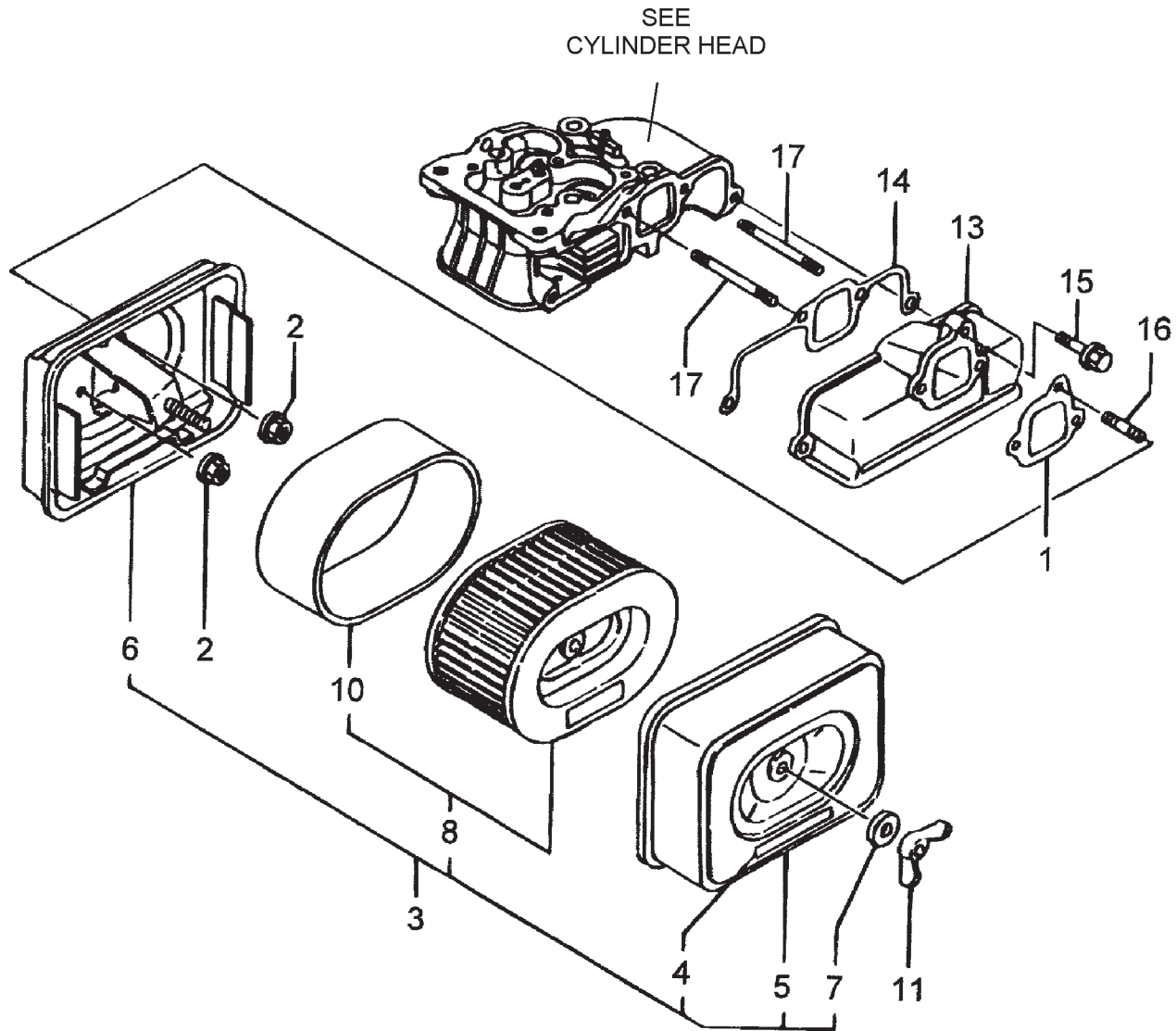

YANMAR L48V6 ENGINE— AIR CLEANER ASSY.

AIR CLEANER ASSY.

<u>NO.</u>	<u>PART NO.</u>	<u>PART NAME</u>	<u>QTY.</u>	<u>REMARKS</u>
1	11429912210	GASKET, AIR CLEANER	1	
2	11429912300	U- NUT	3	
3	11428812511	CLEANER, AIR ASSY.	1	INCLUDES ITEMS W/*
4*	11465007450	LABEL, AIR CLEANER	1	
5*	11428812520	COVER COMPL.	1	
6*	11428812532	CASE, AIR CLEANER	1	
7*	11425212560	SEAL WASHER M8	1	
8*	11465012590	ELEMENT W/ PRE- FILTER	1	INCLUDES ITEMS W/\$
10*\$	11465012550	PRE- FILTER	1	
11	11425212550	WING NUT M8		
13	11477112010	INTAKE MANIFOLD	1	
14	11477112200	AIR INTAKE GASKET	1	
15	26106060252	BOLT M 6X 25 PLATED	2	
16	26226060142	STUD M 6X14 PLATED	1	
17	26226060552	STUD M 6X 55	2	

YANMAR L48V6 ENGINE— MUFFLER ASSY.

MUFFLER ASSY.

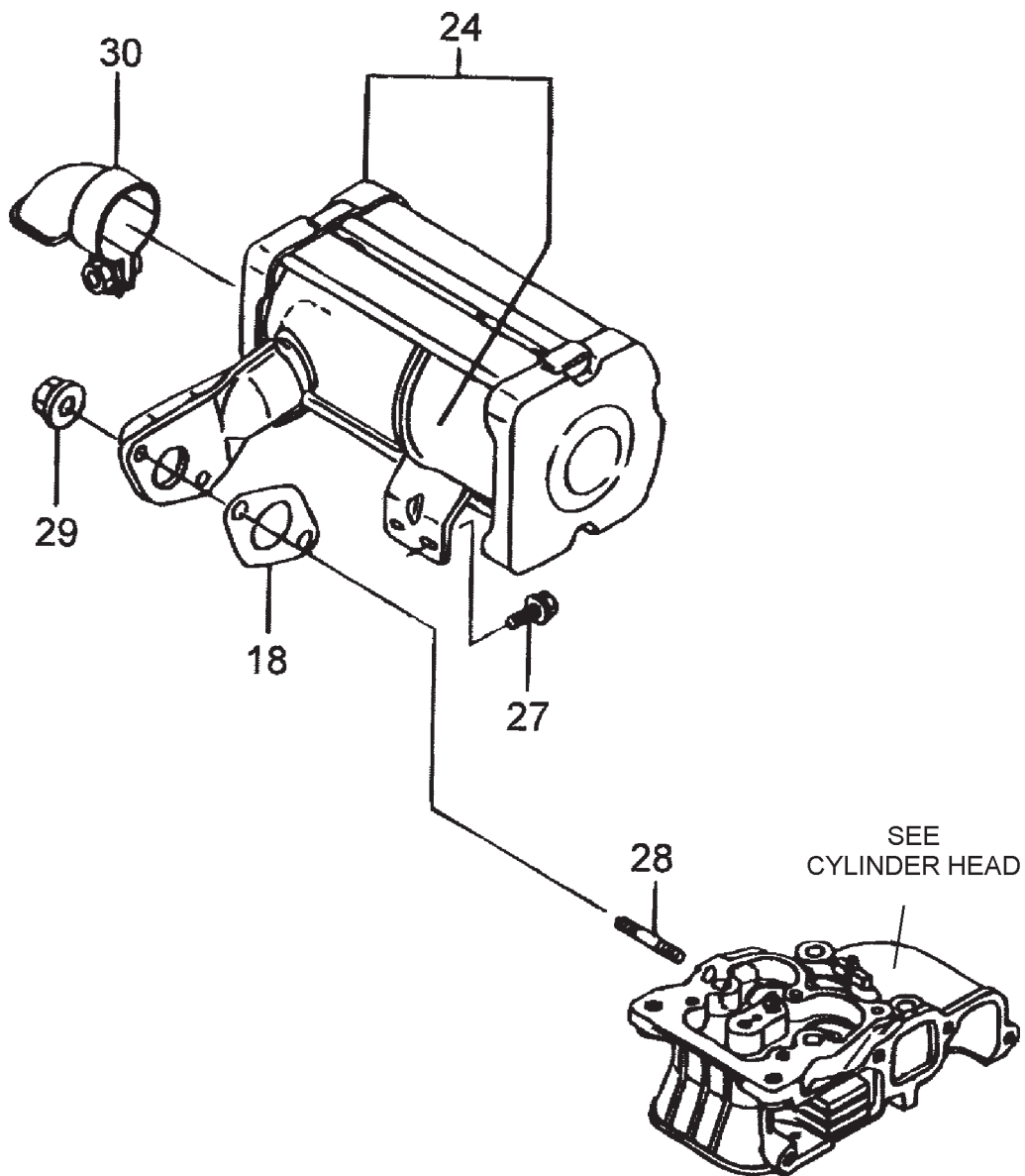

YANMAR L48V6 ENGINE— MUFFLER ASSY.

MUFFLER ASSY.

<u>NO.</u>	<u>PART NO.</u>	<u>PART NAME</u>	<u>QTY.</u>	<u>REMARKS</u>
18	11429913200	MUFFLER GASKET	1	
24	11428813500	MUFFLER ASSY.	1	
27	26106060142	BOLT M6X14 PLATED	2	
28	26216080182	STUD M 8X 18 PLATED	2	
29	26366080002	NUT M 8	2	
30	11429913800	EXHAUST DEFLECTOR	1	

YANMAR L48V6 ENGINE— CRANKSHAFT AND CAMSHAFT ASSY.

CRANKSHAFT AND CAMSHAFT ASSY.

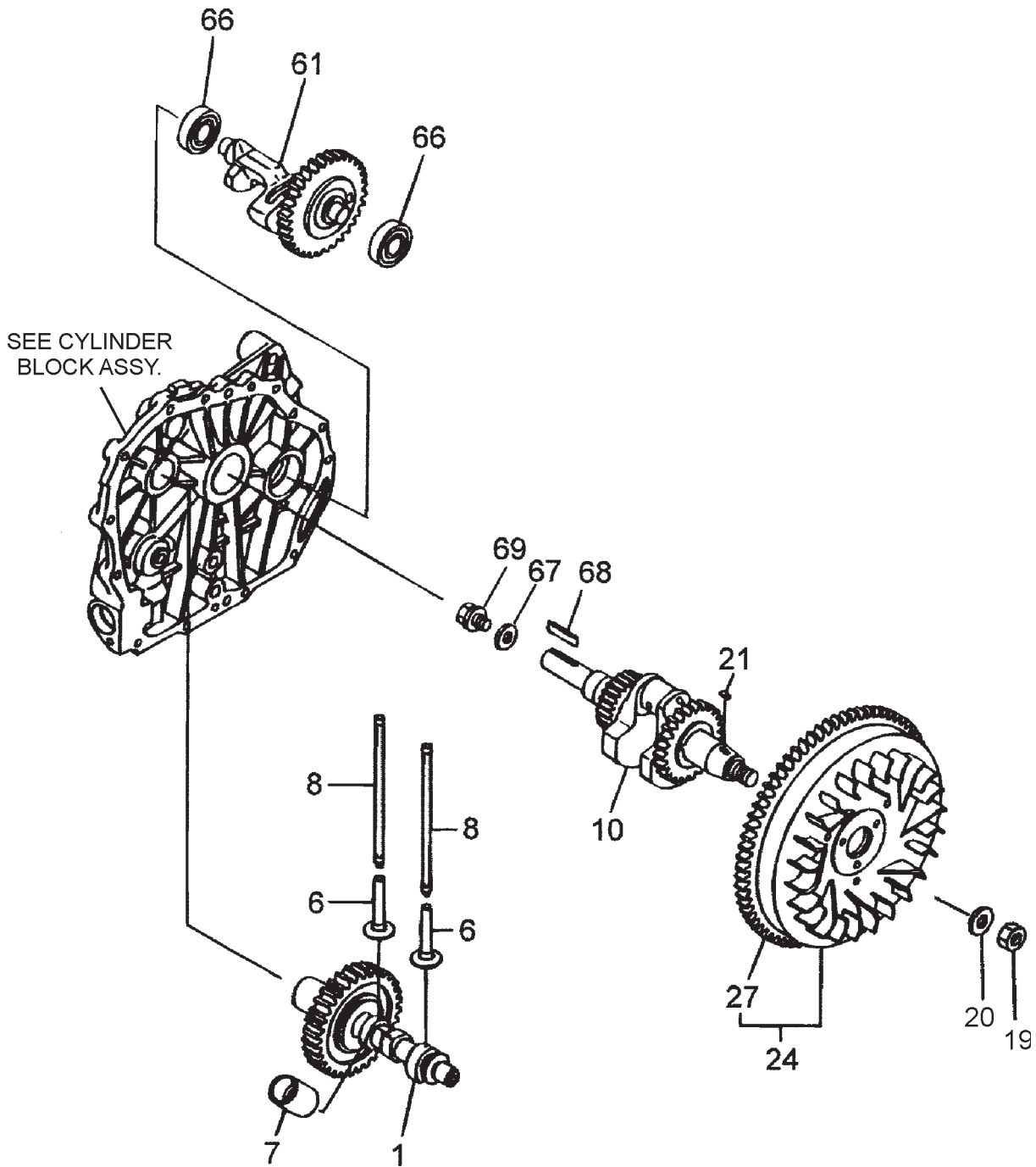

YANMAR L48V6 ENGINE— CRANKSHAFT AND CAMSHAFT ASSY.

PISTON ASSY.

<u>NO.</u>	<u>PART NO.</u>	<u>PART NAME</u>	<u>QTY.</u>	<u>REMARKS</u>
1	71429514580	CAMSHAFT (D) ASSY.	1	
6	11429914200	TAPPET	2	
7	11477114260	TAPPET, F.O.	1	
8	11425014451	PUSH ROD	2	
10	71477221701	CRANKSHAFT ASSY.	1	
19	11429921220	NUT	1	
20	11429921550	FLYWHEEL WASHER	1	
21	22512040120	KEY 4X 12	1	
24	11429921590	FLYWHEEL ASSY.	1	INCLUDES ITEMS W/*
27*	11426221600	RING GEAR	1	
61	71477028531	SHAFT ASSY. BEARING	1	
66	24101062020	BEARING 6202	2	
67	16031014550	WASHER	1	
68	22512050300	KEY 5X30	1	
69	26106080202	BOLT M8 X20 PLATED	1	

YANMAR L48V6 ENGINE— PISTON ASSY.

PISTON ASSY.

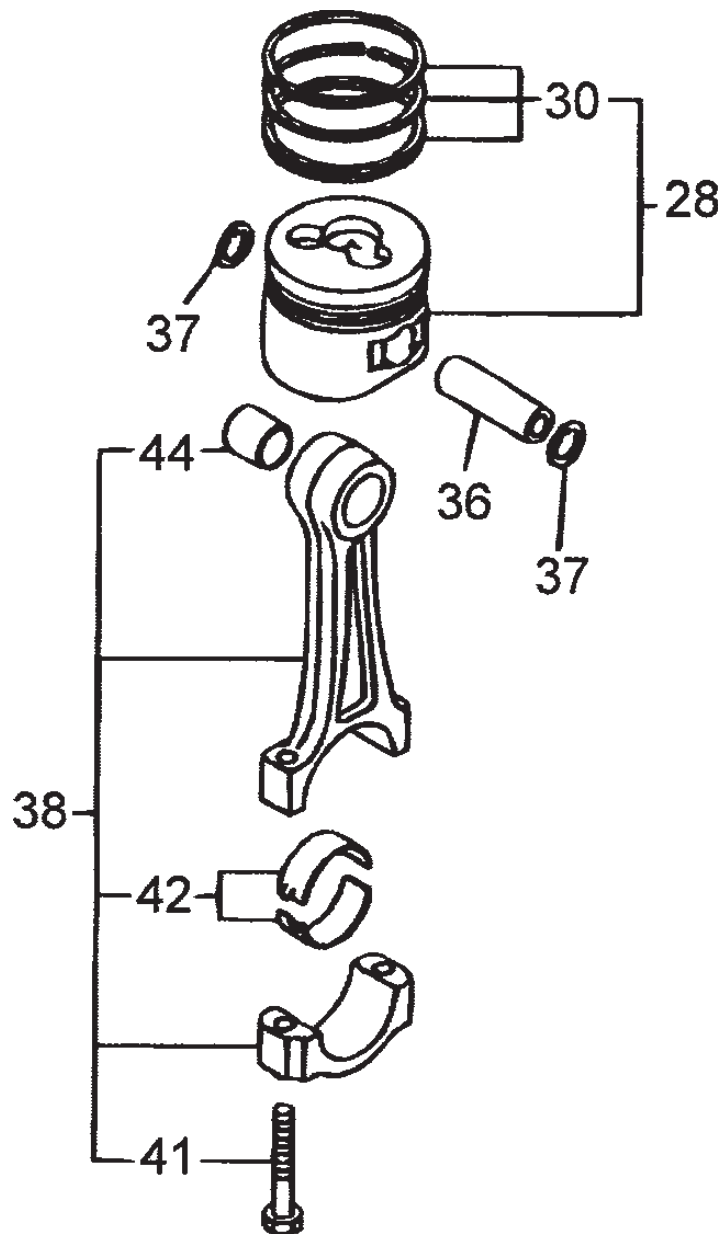

YANMAR L48V6 ENGINE— PISTON ASSY.

PISTON ASSY.

<u>NO.</u>	<u>PART NO.</u>	<u>PART NAME</u>	<u>QTY.</u>	<u>REMARKS</u>
28	71429522720	PISTON W/RINGS (D) STD.	1	INCLUDES ITEMS W/#
28	71429522620	PISTON W/RING OS=0.25	1	INCLUDES ITEMS W/#
28	71429522580	PISTON W/RING OS=0.50	1	INCLUDES ITEMS W/#
30#	71429522500	PISTON RING SET STD.	1	
30#	71429522540	PISTON RING SET OS=0.25	1	
30#	71429522550	PISTON RING SET OS=0.50	1	
36	11429922300	PISTON PIN	1	
37	22252000190	CIRCLIP 19	2	
38	71429923700	CONNECTING ROD ASSY.	1	INCLUDES ITEMS W/*
41*	11926523200	ROD BOLT	2	
42*	71477023600	CRANKPIN BEARING U.S=STD.	1	
42	71477023610	CRANKPIN BEARING U.S=0.25	1	
42	71477023620	CRANKPIN BEARING U.S=0.50	1	
44*	11477023100	PISTON PIN BUSH	1	

YANMAR L48V6 ENGINE— LUB. OIL PUMP AND GOVERNOR ASSY.

LUB. OIL PUMP & GOVERNOR ASSY.

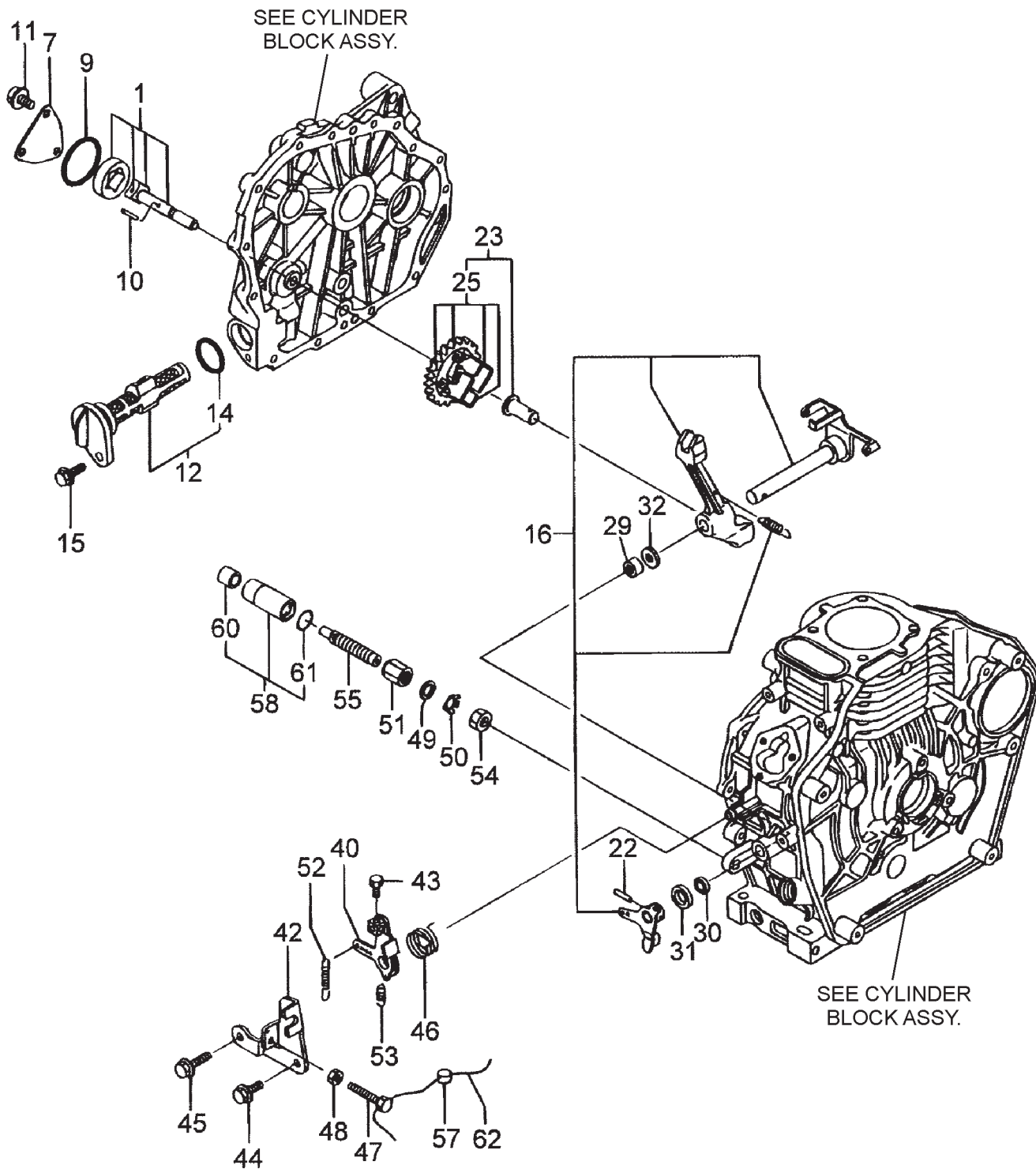

YANMAR L48V6 ENGINE— LUB. OIL PUMP AND GOVERNOR ASSY.

LUB. OIL PUMP & GOVERNOR ASSY.

<u>NO.</u>	<u>PART NO.</u>	<u>PART NAME</u>	<u>QTY.</u>	<u>REMARKS</u>
1	11425032010	LUB. OIL PUMP ASSY.	1	
7	11429932070	LUB. OIL PUMP COVER	1	
9	11429932570	O- RING COVER	1	
10	22312030160	PARALLEL PIN 3X16	1	
11	26106060122	BOLT M 6X 12 PLATED	3	
12	11429935110	LUB. OIL FILTER COMPLETE	1	INCLUDES ITEM W/#
14#	24341000224	O- RING 1A S- 22.4	1	
15	26106060162	BOLT M 6X 16 PLATED	1	
16	11429561190	GOVERNOR LEVER ASSY.	1	
22	22322030200	TAPER PIN 3X20	1	
23	71477061100	GOVERNOR ASSY.	1	INCLUDES ITEM W/*
25*	11477061220	GOVERNOR WEIGHT ASSY.	1	
29	11477061520	NEEDLE BEARING	2	
30	11429961600	OIL SEAL	1	
31	11477061610	THRUST WASHER	1	
32	11429961190	GOVERNOR WASHER	1	
40	11425266051	REGULATOR HANDLE	1	
42	18336060202	REGULATOR BRACKET	1	
43	10522566990	SCREW	1	
44	26106060142	BOLT M 6X 14 PLATED	1	
45	26106060202	BOLT M6X20 PLATED	1	
46	11429966440	RETURN SPRING	1	
47	11429966440	ADJUSTING BOLT	1	
48	26757060002	LOCK NUT M 6 PLATED	2	
49	11477161810	PLAIN WASHER 14	1	
50	11477161830	PLATE	1	
51	11429561940	NUT	1	
52	11429966010	REGULATOR SPRING	1	
53	11429966200	RETURN SPRING	1	
54	11477166690	NUT M14	1	
55	11481866600	FUEL LIMITER ASSY.	1	
57	13521061090	LEAD	1	
58	11477161890	PROTECTOR CMP	1	INCLUDES ITEMS W/+
60+	11477161960	SPACER	1	
61+	24311000180	O- RING 1A P-18.0	1	
62	22451060000	WIRE 0.6	1	

YANMAR L48V6 ENGINE— COOLING AND STARTING DEVICE ASSY.

COOLING AND STARTING DEVICE ASSY.

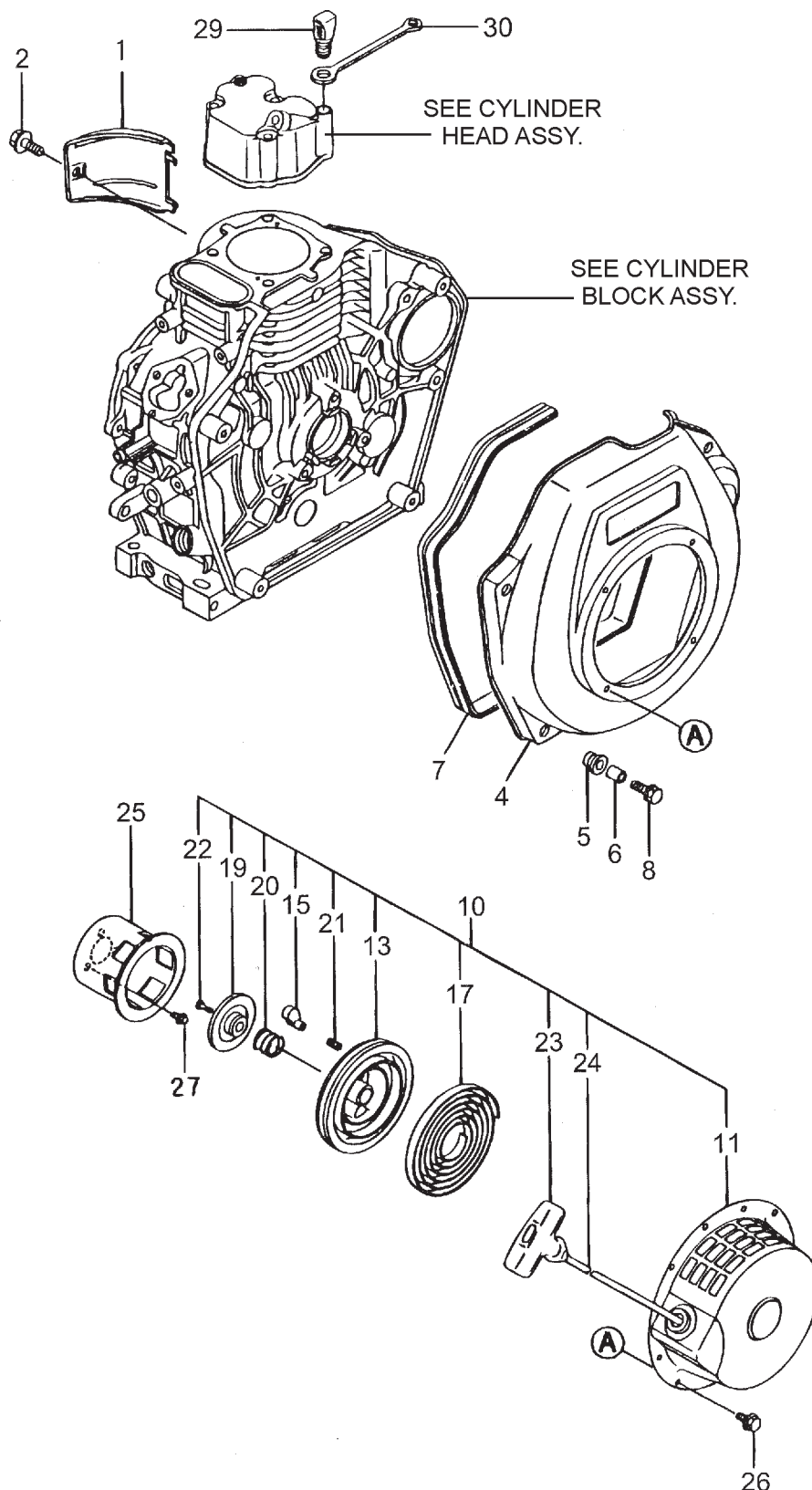

YANMAR L48V6 ENGINE— COOLING AND STARTING DEVICE ASSY.

COOLING & STARTING DEVICE ASSY.

<u>NO.</u>	<u>PART NO.</u>	<u>PART NAME</u>	<u>QTY.</u>	<u>REMARKS</u>
1	11429945210	CYLINDER COVER	1	
2	26106060122	BOLT M 6X12 PLATED	1	
4	11429545100	COOLING FAN CASE	1	
5	11429945300	CUSHION RUBBER	4	
6	11429945310	FAN CASE COLLAR	4	
7	11429945330	FAN CASE SEAL	1	
8	11429945350	FAN CASE BOLT	4	
10	11429976250	RECOIL STARTER (D) ASSY.	1	INCLUDES ITEMS W/*
11*	11429976500	STARTER CASE	1	
13*	11429976520	REEL	1	
15*	11439976530	RATCHET	1	
17*	11439976540	SPIRAL SPRING	1	
19*	11439975550	RATCHET COVER	1	
20*	11439976560	SPRING	1	
21*	11439976570	RETURN SPRING	1	
22*	11439976580	SCREW	1	
23*	11439976620	STARTER KNOB	1	
24*	11429976630	STARTER ROPE	1	
25	11429976590	STARTER PULLEY	1	
26	26106060082	BOLT M 6X 8 PLATED	4	
27	26106060122	BOLT M6X 12 PLATED	3	
29	11429976600	PLUNGER	1	
30	11429976610	PLUNGER HOLDER	1	

YANMAR L48V6 ENGINE— FUEL INJECTION PUMP ASSY.

FUEL INJECTION PUMP ASSY.

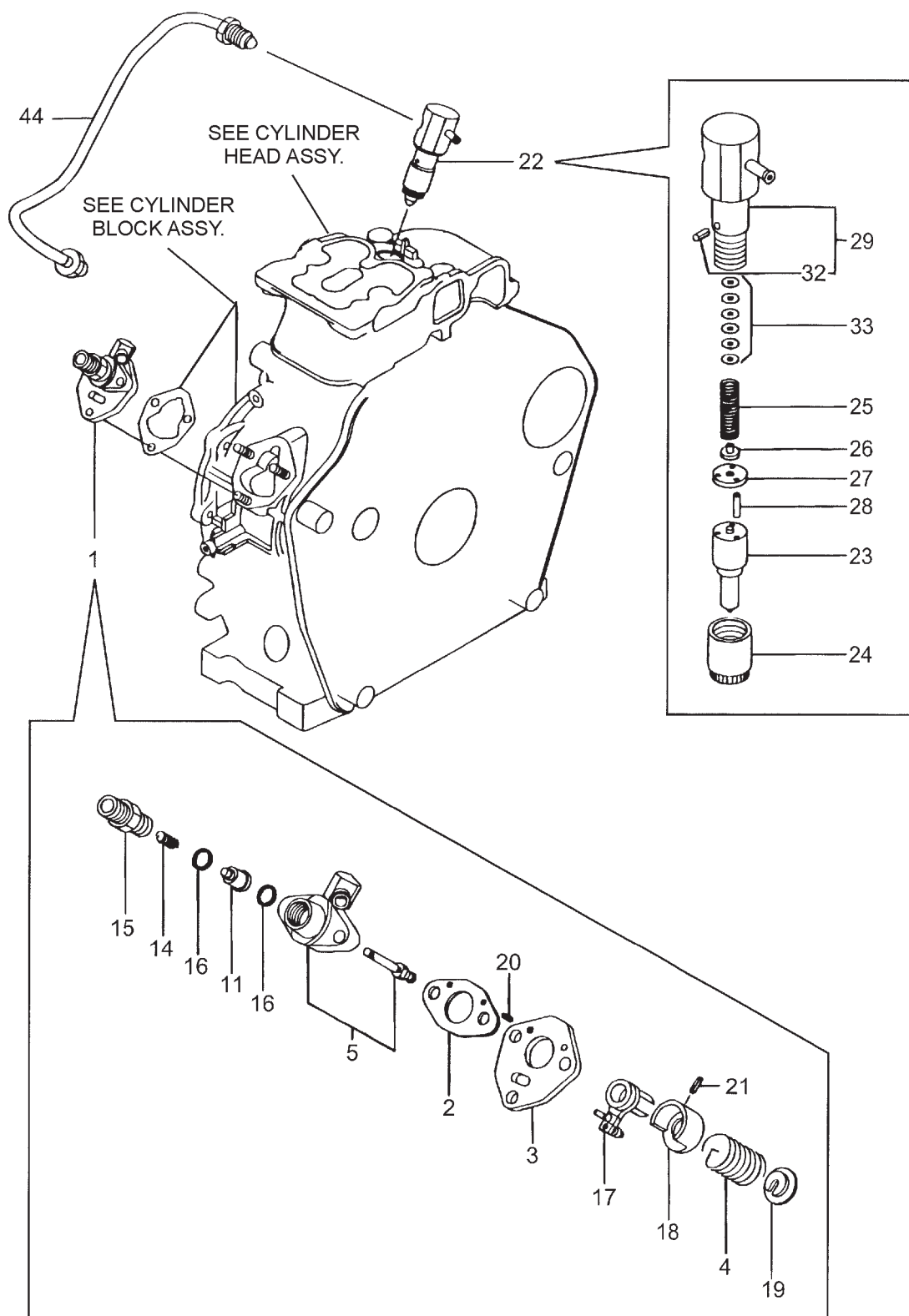

YANMAR L48V6 ENGINE— FUEL INJECTION PUMP ASSY.

FUEL INJECTION PUMP ASSY.

<u>NO.</u>	<u>PART NO.</u>	<u>PART NAME</u>	<u>QTY.</u>	<u>REMARKS</u>
1	71477551100	INJECTION PUMP ASSY., F	1	INCLUDES ITEMS W/*
2*	10554651020	GASKET	1	
3*	11425051080	PLATE	1	
4*	11425051160	SPRING	1	
5*	11435051200	FUEL INJECTION PUMP BODY	1	
11*	11425051300	VALVE ASSY. DELIVERY	1	
14*	10554651330	DELIVERY VALVE SPRING	1	
15*	11425051340	F.I.P. DELIVERY HOLDER	1	
16*	12455051350	DELIVERY GASKET	2	
17*	11425051600	CONTROL LEVER ASSY.	1	
18*	11425051640	SPRING SEAT (A)	1	
19*	11425051650	SPRING SEAT (B)	1	
20*	22351020006	SPRING PIN 2X 6	2	
21*	22351030008	SPRING PIN 3X 8	1	
22	71477553101	FUEL INJECTION VALVE ASSY.	1	INCLUDES ITEMS W/ #
23 #	11477153001	FUEL INJECTION NOZZLE ASSY.	1	
24 #	11959353080	NOZZLE CASE NUT	1	
25 #	11425053120	NOZZLE SPRING	1	
26 #	11959353130	SPRING RETAINER	1	
27 #	11477553140	VALVE STOP SPACER	1	
28 #	11477553210	PIN	2	
29 #	11477553100	HOLDER ASSY.	1	INCLUDES ITEMS W/ %
32 #%	11477553330	PIN	1	
33 #	11425053400	SHIM PACK	1	
44	11477159803	FUEL INJECTION PIPE	1	

YANMAR L48V6 ENGINE— FUEL TANK & FUEL LINE ASSY.

FUEL TANK AND FUEL LINE ASSY.

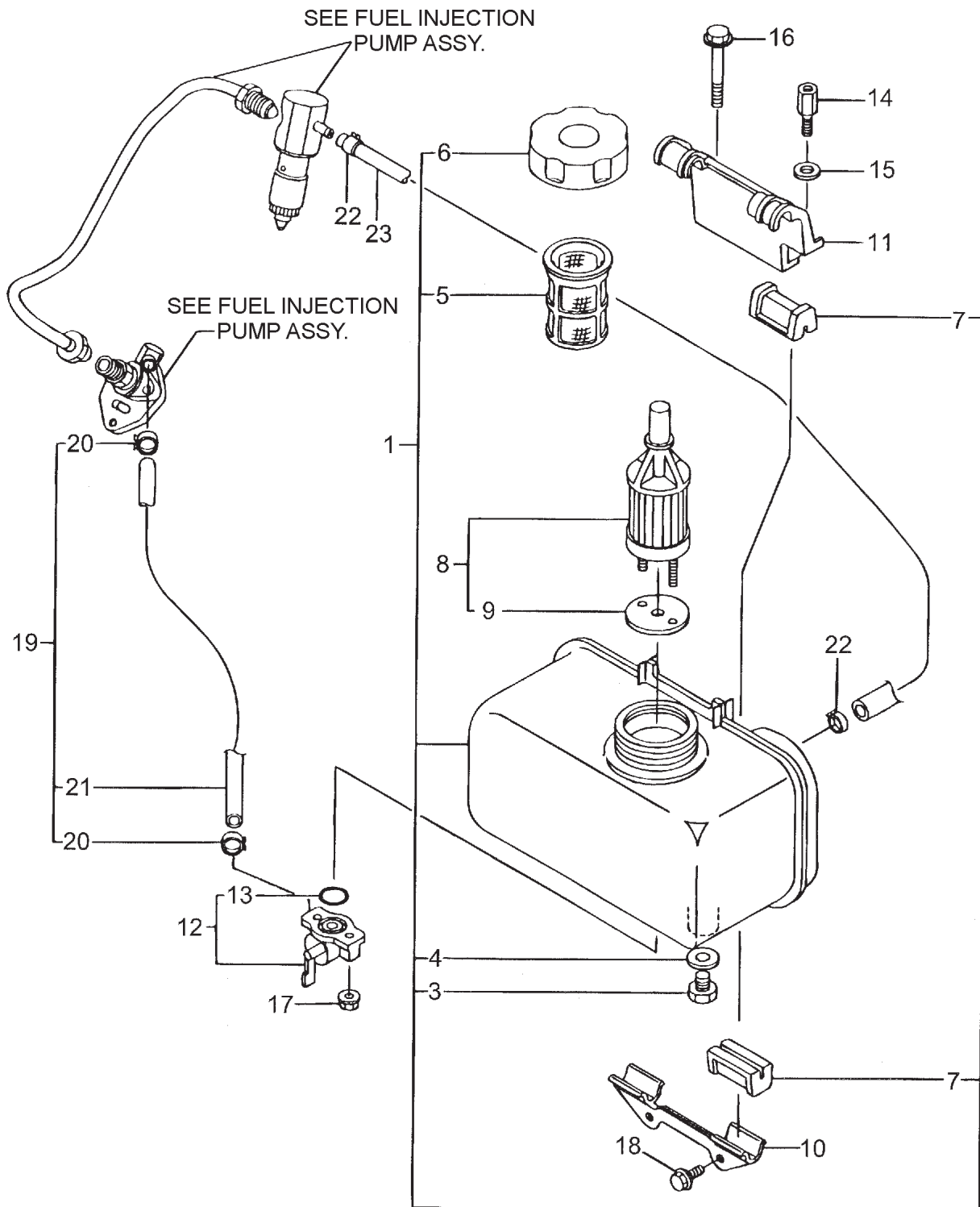

YANMAR L48V6 ENGINE — FUEL TANK AND FUEL LINE ASSY.

FUEL TANK & FUEL LINE ASSY.

<u>NO.</u>	<u>PART NO.</u>	<u>PART NAME</u>	<u>QTY.</u>	<u>REMARKS</u>
1	71429955720	FUEL TANK, BLACK	1	INCLUDES ITEMS W/ #
3#	10530055080	DRAIN PLUG	1	
4#	23414080000	ROUND GASKET 8	1	
5#	11429955100	FILTER, FUEL OIL	1	
6#	11429955040	FUEL TANK CAP ASSY.	1	
7#	11429955201	FUEL TANK DAMPER	4	
8	11425055121	FILTER, FUEL STRAINER	1	INCLUDES ITEM W/ %
9%	11425055130	GASKET	1	
10#	11429955210	STAY	1	
11	11429955230	STAY (B)	1	
12	11425055301	COCK	1	INCLUDES ITEM W/+
13+	24341000150	O- RING 1A S- 15.0	1	
14	11429955810	LIFTING BOLT	1	
15	22117080000	WASHER 8	1	
16	26106080452	BOLT M 8X 45 PLATED	1	
17	26368060002	NUT M6	2	
18	26106060162	BOLT M6X 16 PLATED	2	
19	11477059030	FUEL OIL PIPE ASSY.	1	INCLUDES ITEMS W/*
20*	11427059010	HOSE CLIP	2	
21*	11426859061	FUEL OIL PIPE	1	
22	12472259050	CLAMP 9	2	
23	11425059060	FUEL RETURN PIPE	1	

YANMAR L48V6—TOOLS, LABELS AND GASKETS SET ASSY.

TOOLS, LABELS AND GASKET SET ASSY.

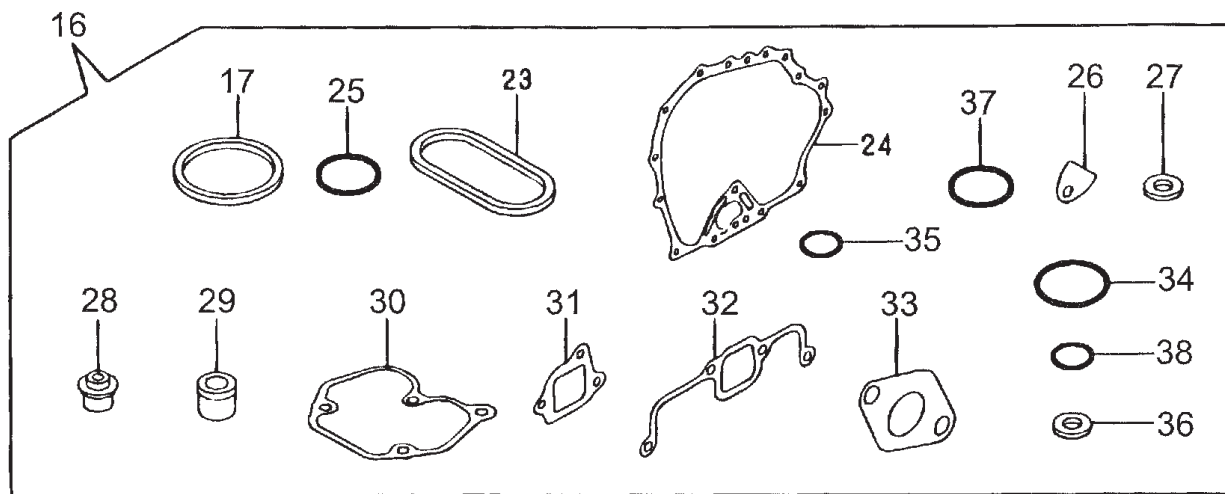
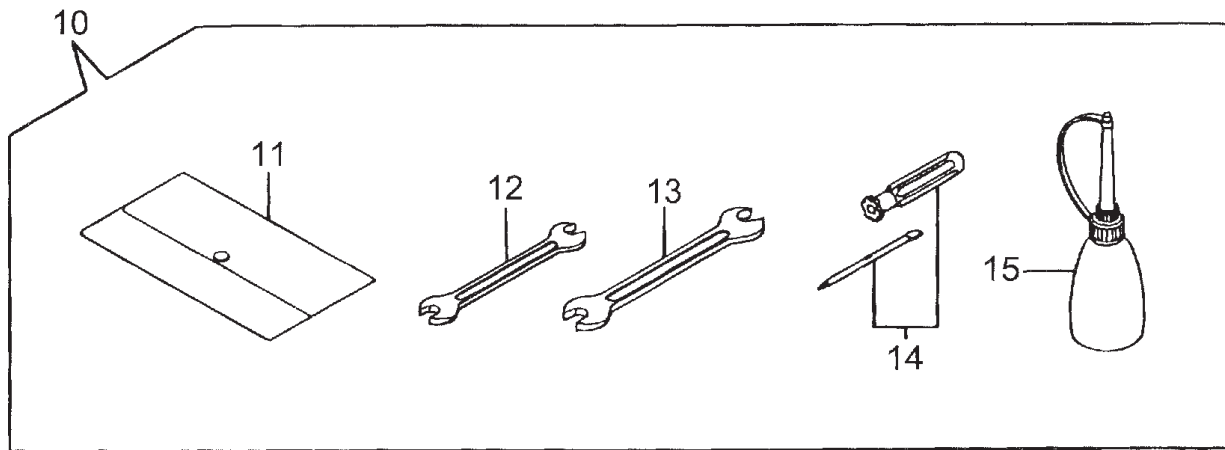
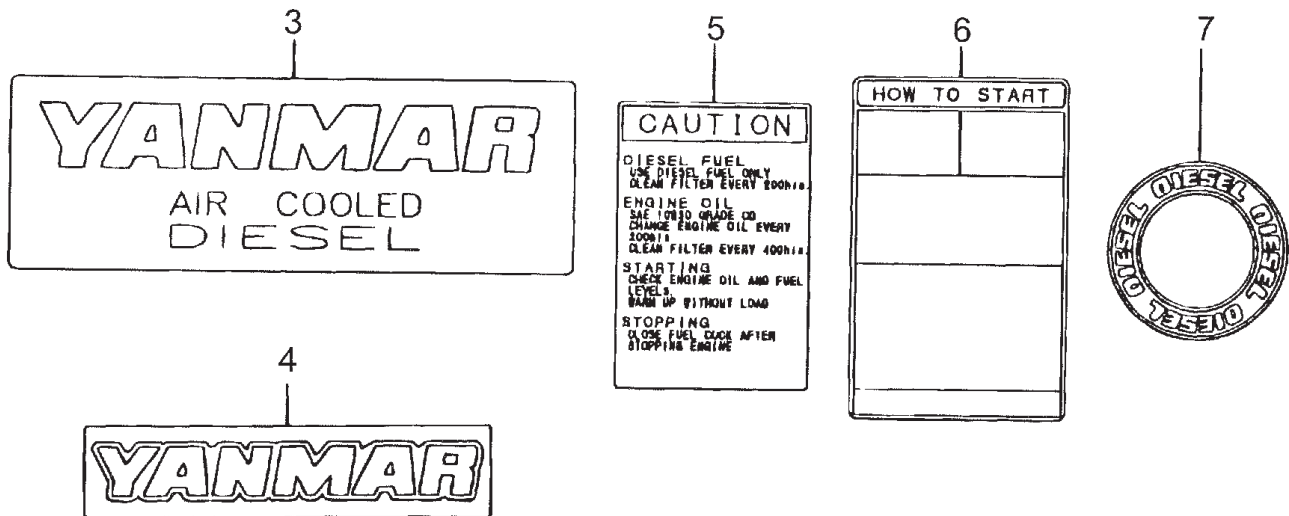

YANMAR L48V6 ENGINE—TOOLS, LABELS AND GASKETS SET ASSY.

TOOLS, LABELS AND GASKET SET ASSY.

<u>NO.</u>	<u>PART NO.</u>	<u>PART NAME</u>	<u>QTY.</u>	<u>REMARKS</u>
3	11429907100	AIR COOLED LABEL	1	
4	11429907110	YANMAR LABEL	1	
5	11421007120	CAUTION LABEL	1	
6	11421007130	HOW TO START -E LABEL	1	
7	11429907160	DIESEL LABEL	1	
10	11429992590	TOOL ASSY.....	1	INCLUDES ITEMS W/*
11*	11429992600	TOOL BAG	1	
12*	11429992710	SPANNA	1	
13*	11429992720	SPANNA	1	
14*	11429992730	DRIVER	1	
15*	11429992740	FUEL FITTING	1	
16	71411092600	GASKET SET	1	INCLUDES ITEMS W/#
17#	11429501330	CYLINDER HEAD GASKET ASSY.	1	
23#	11429901280	O- RING	1	
24#	11429901410	CRANK CASE GASKET	1	
25#	11429901950	O- RING	2	
26#	11425001841	GASKET	1	
27#	22190160002	WASHER SEAL 16S	2	
28#	11425011340	VALVE STEM SEAL	2	
29#	11477111461	NOZZLE GASKET	1	
30#	11477111310	BONNET GASKET	1	
31#	11429912210	AIR CLEANER GASKET	1	
32#	11477112200	AIR INTAKE GASKET	1	
33#	11429913200	MUFFLER GASKET	1	
34#	11429932570	O- RING, COVER	1	
35#	24341000100	O- RING 1A S-10.0	1	
36#	23414080000	PACKING 8	1	
37#	24341000224	O- RING 1A S- 22.4	1	
38#	24341000150	O- RING 1A S- 15.0	1	

PAYMENT TERMS

Terms of payment for parts are net 30 days.

FREIGHT POLICY

All parts orders will be shipped collect or prepaid with the charges added to the invoice. All shipments are F.O.B. point of origin. Multiquip's responsibility ceases when a signed manifest has been obtained from the carrier, and any claim for shortage or damage must be settled between the consignee and the carrier.

MINIMUM ORDER

The minimum charge for orders from Multiquip is \$15.00 net. Customers will be asked for instructions regarding handling of orders not meeting this requirement.

RETURNED GOODS POLICY

Return shipments will be accepted and credit will be allowed, subject to the following provisions:

1. A Returned Material Authorization must be approved by Multiquip prior to shipment.
2. To obtain a Return Material Authorization, a list must be provided to Multiquip Parts Sales that defines item numbers, quantities, and descriptions of the items to be returned.
 - a. The parts numbers and descriptions must match the current parts price list.
 - b. The list must be typed or computer generated.
 - c. The list must state the reason(s) for the return.
 - d. The list must reference the sales order(s) or invoice(s) under which the items were originally purchased.
 - e. The list must include the name and phone number of the person requesting the RMA.
3. A copy of the Return Material Authorization must accompany the return shipment.
4. Freight is at the sender's expense. All parts must be returned freight prepaid to Multiquip's designated receiving point.

5. Parts must be in new and resalable condition, in the original Multiquip package (if any), and with Multiquip part numbers clearly marked.
6. The following items are not returnable:
 - a. Obsolete parts. (If an item is in the price book and shows as being replaced by another item, it is obsolete.)
 - b. Any parts with a limited shelf life (such as gaskets, seals, "O" rings, and other rubber parts) that were purchased more than six months prior to the return date.
 - c. Any line item with an extended dealer net price of less than \$5.00.
 - d. Special order items.
 - e. Electrical components.
 - f. Paint, chemicals, and lubricants.
 - g. Decals and paper products.
 - h. Items purchased in kits.
7. The sender will be notified of any material received that is not acceptable.
8. Such material will be held for five working days from notification, pending instructions. If a reply is not received within five days, the material will be returned to the sender at his expense.
9. Credit on returned parts will be issued at dealer net price at time of the original purchase, less a 15% restocking charge.
10. In cases where an item is accepted, for which the original purchase document can not be determined, the price will be based on the list price that was effective twelve months prior to the RMA date.
11. Credit issued will be applied to future purchases only.

PRICING AND REBATES

Prices are subject to change without prior notice. Price changes are effective on a specific date and all orders received on or after that date will be billed at the revised price. Rebates for price declines and added charges for price increases will not be made for stock on hand at the time of any price change.

Multiquip reserves the right to quote and sell direct to Government agencies, and to Original Equipment Manufacturer accounts who use our products as integral parts of their own products.

SPECIAL EXPEDITING SERVICE

A \$35.00 surcharge will be added to the invoice for special handling including bus shipments, insured parcel post or in cases where Multiquip must personally deliver the parts to the carrier.

LIMITATIONS OF SELLER'S LIABILITY

Multiquip shall not be liable hereunder for damages in excess of the purchase price of the item with respect to which damages are claimed, and in no event shall Multiquip be liable for loss of profit or good will or for any other special, consequential or incidental damages.

LIMITATION OF WARRANTIES

No warranties, express or implied, are made in connection with the sale of parts or trade accessories nor as to any engine not manufactured by Multiquip. Such warranties made in connection with the sale of new, complete units are made exclusively by a statement of warranty packaged with such units, and Multiquip neither assumes nor authorizes any person to assume for it any other obligation or liability whatever in connection with the sale of its products. Apart from such written statement of warranty, there are no warranties, express, implied or statutory, which extend beyond the description of the products on the face hereof.

OPERATION AND PARTS MANUAL

HERE'S HOW TO GET HELP

PLEASE HAVE THE MODEL AND SERIAL
NUMBER *ON-HAND* WHEN CALLING

UNITED STATES

Multiquip Corporate Office

18910 Wilmington Ave. Tel. (800) 421-1244
Carson, CA 90746 Fax (800) 537-3927
Contact: mq@multiquip.com

Mayco Parts

800-306-2926 Fax: 800-672-7877
310-537-3700 Fax: 310-637-3284

Service Department

800-421-1244 Fax: 310-537-4259
310-537-3700

MQ Parts Department

800-427-1244 Fax: 800-672-7877
310-537-3700 Fax: 310-637-3284

Warranty Department

800-421-1244, Ext. 279 Fax: 310-537-1173
310-537-3700, Ext. 279

Technical Assistance

800-478-1244 Fax: 310-631-5032

MEXICO

MQ Cipsa

Carr. Fed. Mexico-Puebla KM 126.5 Tel: (52) 222-225-9900
Momoxpan, Cholula, Puebla 72760 Mexico Fax: (52) 222-285-0420
Contact: pmastretta@cipsa.com.mx

CANADA

Multiquip

4110 Industriel Boul. Tel: (450) 625-2244
Laval, Quebec, Canada H7L 6V3 Fax: (450) 625-8664
Contact: jmartin@multiquip.com

UNITED KINGDOM

Multiquip (UK) Limited Head Office

Hanover Mill, Fitzroy Street, Tel: 0161 339 2223
Ashton-under-Lyne, Fax: 0161 339 3226
Lancashire OL7 0TL
Contact: sales@multiquip.co.uk

BRAZIL

Multiquip

Av. Evandro Lins e Silva, 840 - grupo 505 Tel: 011-55-21-3433-9055
Barra de Tijuca - Rio de Janeiro Fax: 011-55-21-3433-9055
Contact: cnavarro@multiquip.com.br, srentes@multiquip.com.br

© COPYRIGHT 2007, MULTQUIP INC.

Multiquip Inc, the MQ logo and the Mikasa logo are registered trademarks of Multiquip Inc. and may not be used, reproduced, or altered without written permission. All other trademarks are the property of their respective owners and used with permission.

This manual MUST accompany the equipment at all times. This manual is considered a permanent part of the equipment and should remain with the unit if resold.

The information and specifications included in this publication were in effect at the time of approval for printing. Illustrations are based on the *MQ Mikasa MVH-150D2 Reversible Plate Compactor*. Illustrations, descriptions, references and technical data contained in this manual are for guidance only and may not be considered as binding. Multiquip Inc. reserves the right to discontinue or change specifications, design or the information published in this publication at any time without notice and without incurring any obligations.

Your Local Dealer is:

